

SMART
SENSOR
BUSINESS

MA 235i

Fieldbus Gateway – CANopen

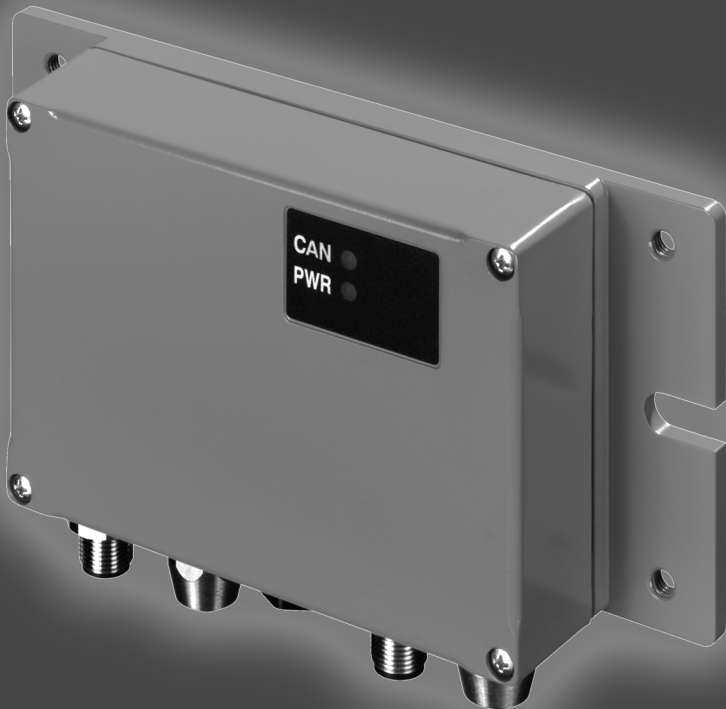

en 04-2017/01_50120388
We reserve the right to
make technical changes

1	General information	5
1.1	Explanation of symbols	5
1.2	Declaration of Conformity	5
1.3	Description of functions	6
1.4	Definition of terms	7
2	Safety	8
2.1	Intended use	8
2.2	Foreseeable misuse	8
2.3	Competent persons	9
2.4	Disclaimer	9
3	Fast commissioning / operating principle	10
3.1	Mounting	10
3.2	Device arrangement and selection of the mounting location	10
3.3	Electrical connection	10
3.3.1	Connecting the Leuze device	11
3.3.2	Connecting the power supply and the bus cable	13
3.4	Starting the device	13
3.5	MA 235 <i>i</i> on the CANopen	13
4	Device description	14
4.1	General Information to the connector units	14
4.2	Characteristics of the connector units	14
4.3	Device construction	15
4.4	Operating modes	16
4.5	Fieldbus systems	17
4.5.1	CANopen	17
5	Specifications	21
5.1	General specifications	21
5.2	Dimensioned drawings	22
5.3	Type overview	23
6	Installation and mounting	24
6.1	Storage, transportation	24

6.2	Mounting	25
6.3	Device arrangement	26
6.3.1	Selecting a mounting location	26
6.4	Cleaning	26
7	Electrical connection	27
7.1	Safety notices for the electrical connection	27
7.2	Electrical connection	28
7.2.1	PWR IN – voltage supply / switching input/output	28
7.2.2	PWR OUT switching input/output	30
7.3	BUS IN	30
7.4	BUS OUT	31
7.4.1	Termination of the CANopen bus	31
7.5	Device interfaces	32
7.5.1	RS 232 device interface (accessible after opening the device, internal)	32
7.5.2	Service interface (internal)	33
8	Status displays and operational controls	34
8.1	LED status indicators	34
8.1.1	LED indicators on the circuit board	34
8.1.2	LED indicators on the housing	35
8.2	Internal interfaces and operational controls	36
8.2.1	Overview of operational controls of the	36
8.2.2	Connector X30 ... connectors	38
8.2.3	RS 232 service interface – X33	38
8.2.4	S10 service switch	38
8.2.5	Rotary switch S4 for device selection	39
8.2.6	Switch for address selection in the fieldbus	40
8.2.7	Switch for setting the baud rate	40
9	Configuration	41
9.1	Connecting the service interface	41
9.2	Reading out information in Service mode	41
10	Telegram	44
10.1	Structure of the fieldbus telegram	44
10.2	Description of the input bytes (status bytes)	45
10.2.1	Structure and meaning of the input bytes (status bytes)	45
10.2.2	Detailed description of the bits (input byte 0)	46

10.2.3	Detailed description of the bits (input byte 1)	48
10.3	Description of the output bytes (control bytes)	48
10.3.1	Structure and meaning of the output bytes (control bytes)	48
10.3.2	Detailed description of the bits (output byte 0)	49
10.3.3	Detailed description of the bits (output byte 1)	50
10.4	RESET function / deleting memory	51
11	Modes	52
11.1	Functionality of the data exchange	52
11.1.1	Reading slave data in Collective mode (gateway -> PLC)	53
11.1.2	Writing slave data in Collective mode (PLC -> gateway)	53
11.1.3	Command mode	56
12	Commissioning and configuration	58
12.1	Measures to be performed prior to the initial commissioning	58
12.1.1	Connecting the power supply and the bus cable	60
12.2	Starting the device	60
12.3	MA 235<i>i</i> in the CANopen system	61
12.4	Starting the MA 235<i>i</i> in the CANopen system	62
12.4.1	Device profile	62
12.4.2	Object directories	63
12.4.3	SDOs and PDOs	63
12.4.4	SDOs	63
12.4.5	PDOs	64
12.4.6	Object index	65
12.5	Setting the read parameters on the Leuze device	69
12.5.1	Specific feature for the use of hand-held scanners (bar code and 2D devices, combi devices with RFID)	70
12.5.2	Specific features in the operation of an RFM/RFI	71
13	Diagnostics and troubleshooting	72
13.1	General causes of errors	72
13.2	Interface errors	73
14	Type overview and accessories	74
14.1	Part number code	74
14.2	Type overview	74
14.3	Accessory terminating resistor	74
14.4	Accessory connectors	74

14.5	Accessory ready-made cables for voltage supply	75
14.5.1	Contact assignment of PWR connection cable	75
14.5.2	Specifications of the cables for voltage supply	75
14.5.3	Order codes of the cables for voltage supply	76
14.6	Accessory ready-made cables for bus connection	76
14.6.1	General information	76
14.6.2	Contact assignment of M12-CANopen connection cable KB DN	76
14.6.3	Specifications of M12-CANopen connection cable KB DN	77
14.6.4	Order codes of M12-CANopen connection cable KB DN	77
14.7	Accessory ready-made cables for connecting Leuze Ident devices	78
14.7.1	Order codes for the device connection cables	78
14.7.2	Contact assignment for the device connection cables	78
15	Maintenance	79
15.1	General maintenance information	79
15.2	Repairs, servicing	79
15.3	Disassembling, packing, disposing	79
16	Specifications for Leuze end devices	80
16.1	Standard setting, KONTURflex (S4 switch position 0)	80
16.2	Bar code reader BCL 8 (S4 switch position 1)	82
16.3	Bar code reader BCL 22 (S4 switch position 2)	83
16.4	Bar code reader BCL 300i, BCL 500i, BCL 600i (S4 switch position 4)	84
16.5	Bar code reader BCL 90, BCL 900i (S4 switch position 5)	85
16.6	LSIS 122, LSIS 222 (S4 switch position 6)	86
16.7	LSIS 4x2i, DCR 202i (S4 switch position 7)	87
16.8	Hand-held scanner (S4 switch position 8)	88
16.9	RFI, RFM, RFU RFID readers (S4 switch position 9)	89
16.10	BPS 8 bar code positioning system (S4 switch position A)	90
16.11	BPS 300i bar code positioning system, ODSL xx optical distance sensors with RS 232 interface (S4 switch position B)	91
16.12	Modular interfacing unit MA 3x (S4 switch position C)	93
16.13	Resetting the parameters (S4 switch position F)	94
17	Appendix	95
17.1	ASCII Table	95

1 General information

1.1 Explanation of symbols

The symbols used in this operating manual are explained below.



Attention!

This symbol precedes text messages which must strictly be observed. Failure to comply with this information results in injuries to persons or damage to the equipment.



Notice!

This symbol indicates text passages containing important information.

1.2 Declaration of Conformity

The MA 235*i* modular interfacing units have been designed and manufactured in accordance with applicable European directives and standards.



Notice!

The Declaration of Conformity for these devices can be requested from the manufacturer.

The manufacturer of the product, Leuze electronic GmbH + Co. KG in D-73277 Owen, possesses a certified quality assurance system in accordance with ISO 9001.

The modular interfacing unit is "UL LISTED" in accordance with American and Canadian safety standards and fulfills requirements of Underwriter Laboratories Inc. (UL).



1.3 Description of functions

The MA 235*i* modular interfacing unit is used to connect Leuze devices directly to the fieldbus.

Bar code reader:	BCL 8, 22, 300i, 500i, 600i, 90, 900i
2D-code reader:	LSIS 122, LSIS 222, LSIS 4x2i, DCR 200i
Hand-held scanner	ITxxxx, HFU/HFM
RFID read-write devices:	RFM 12, 32, 62 & RFI 32, RFU 100, RFU 200
Bar code positioning system:	BPS 8, BPS 300
Optical distance sensors:	ODSL 9, ODSL 30, ODSL 96B
Measuring light curtain:	KONTURflex to Quattro-RSX/M12
multiNet master connection box:	MA 3x
Additional RS 232 devices:	Scales, third-party devices

This is accomplished by transmitting the data from the DEV via an RS 232 (V.24) interface to the MA 235*i* where a module converts it into the CANopen format. The data format on the RS 232 interface corresponds to the Leuze standard data format (9600bd, 8N1 and STX, data, CR, LF).

The corresponding Leuze devices are selected using a rotary code switch on the circuit board of the connector unit. Many additional RS 232 devices can be connected through a universal position.

Leuze electronic can only provide support for the devices offered in the product range.

1.4 Definition of terms

For better understanding of the explanations provided in this document, a definition of terms follows below:

- **Bit designation:**
The 1st bit or byte begins with count number "0" and means bit/byte 2^0 .
- **Data length:**
Size of a valid, continuous data packet in bytes.
- **EDS file (electronic data sheet):**
Description of the device for the control.
- **Consistent:**
Data which belongs together with regard to content and which must not be separated is referred to as consistent data. When identifying objects, it must be ensured that the data is transmitted completely and in the correct order, otherwise the result is falsified.
- **Leuze device (DEV):**
Leuze devices, e.g., bar code readers, RFID readers, VisionReader...
- **Online command:**
These commands refer to the respective, connected ident device and may be different depending on the device. These commands are not interpreted by the MA 235*i*, but are instead transmitted transparently (see description of Ident device).
- **CR:**
Cross reference.
- **Perspective of I/O data in the description:**
Output data is data which is sent by the control to the MA. Input data is data which is sent by the MA to the control.
- **Toggle bits:**
 - Status toggle bit**
Each change of state indicates that an action was performed, e.g., bit ND (new data): each change of state indicates that new received data was transmitted to the PLC.
 - Control toggle bit**
An action is performed on each change of state, e.g., bit SDO: on each change of state, the registered data is sent by the PLC to the MA 235*i*.

2 Safety

This device was developed, manufactured and tested in line with the applicable safety standards. It corresponds to the state of the art.

2.1 Intended use

The MA 235*i* modular interfacing unit is used for connecting Leuze devices such as bar code or 2D-code readers, hand-held scanners, RFID read-write devices, etc. directly to the fieldbus.

	CAUTION
Observe intended use!	
<p>↪ Only operate the device in accordance with its intended use. The protection of personnel and the device cannot be guaranteed if the device is operated in a manner not complying with its intended use.</p> <p>Leuze electronic GmbH + Co. KG is not liable for damages caused by improper use.</p> <p>↪ Read the technical description before commissioning the device. Knowledge of this technical description is an element of proper use.</p>	

NOTICE	
Comply with conditions and regulations!	
<p>↪ Observe the locally applicable legal regulations and the rules of the employer's liability insurance association.</p>	



Attention

For UL applications, use is permitted exclusively in Class 2 circuits according to NEC (National Electric Code).

2.2 Foreseeable misuse

Any use other than that defined under "Intended use" or which goes beyond that use is considered improper use.

In particular, use of the device is not permitted in the following cases:

- Rooms with explosive atmospheres
- As stand-alone safety component in accordance with the machinery directive ¹⁾
- For medicinal purposes

1) Use as safety-related component within the safety function is possible, if the component combination is designed correspondingly by the machine manufacturer.

NOTICE

Do not modify or otherwise interfere with the device.

- ✎ Do not carry out modifications or otherwise interfere with the device.
The device must not be tampered with and must not be changed in any way.
The device must not be opened. There are no user-serviceable parts inside.
Repairs must only be performed by Leuze electronic GmbH + Co. KG.

2.3 Competent persons

Connection, mounting, commissioning and adjustment of the device must only be carried out by competent persons.

Prerequisites for competent persons:

- They have a suitable technical education.
- They are familiar with the rules and regulations for occupational safety and safety at work.
- They are familiar with the technical description of the device.
- They have been instructed by the responsible person on the mounting and operation of the device.

Certified electricians

Electrical work must be carried out by a certified electrician.

Due to their technical training, knowledge and experience as well as their familiarity with relevant standards and regulations, certified electricians are able to perform work on electrical systems and independently detect possible dangers.

In Germany, certified electricians must fulfill the requirements of accident-prevention regulations BGV A3 (e.g. electrician foreman). In other countries, there are respective regulations that must be observed.

2.4 Disclaimer

Leuze electronic GmbH + Co. KG is not liable in the following cases:

- The device is not being used properly.
- Reasonably foreseeable misuse is not taken into account.
- Mounting and electrical connection are not properly performed.
- Changes (e.g., constructional) are made to the device.

3 Fast commissioning / operating principle



Notice!

Below you will find a **short description for the initial commissioning** of the CANopen gateway MA 235*i*. Detailed explanations for the listed points can be found throughout the handbook.

3.1 Mounting

The gateway mounting plate MA 235*i* can be mounted in two different ways:

- using four threaded holes (M6) or
- using two M8x6 screws on the two lateral grooves.

3.2 Device arrangement and selection of the mounting location

Ideally, the MA 235*i* should be mounted so that it is easily accessible near the Ident device in order to ensure good operability, e.g., for configuring the connected device.

Detailed information can be found in chapter 6.3.1.

3.3 Electrical connection

The devices from the MA 2xx*i* family feature four M12 connectors/sockets which are coded differently depending on the interface.

The voltage supply (**PWR IN**) as well as the switching inputs/outputs (**PWR OUT** or **PWR IN**) are connected there. The number and function of the switching inputs/outputs is dependent on the connected end device.

An internal RS 232 interface is used for connecting the respective Leuze device. Another internal RS 232 interface functions as a service interface for configuring the connected device via a serial null modem cable.

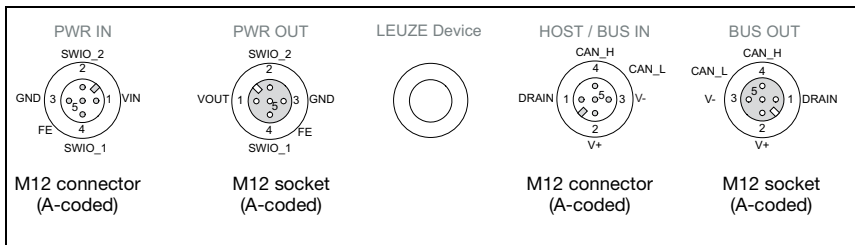

Figure 3.1: MA 235*i* connections

Detailed information can be found in chapter 7.

3.3.1 Connecting the Leuze device

- ↳ To connect the Leuze device to the internal RS 232 device interface, open the housing of the MA 235*i* and lead the corresponding device cable (see chapter 14.7) through the middle threaded opening.
- ↳ Connect the cable to the internal device interface (**X30, X31** or **X32**, see chapter 7.5.1).
- ↳ Use rotary switch **S4** (see chapter 8.2.5) to select the connected device.
- ↳ Now screw the PG cable gland into the threaded opening to provide strain relief and ensure protection class IP 65.

Set CANopen device address

By setting the CANopen address, the MA 235*i* is assigned its respective station number. Each network device is thereby automatically informed that it is a slave on the CANopen with its specific address and that it is initialized and queried by the PLC.

The CANopen permits an address range from 0 to 127, the MA a range from 0 to 99. Other addresses must not be used for data communication.

- ↳ Set the station address of the gateway using the two rotary switches **S1** and **S2** (ones and tens places).

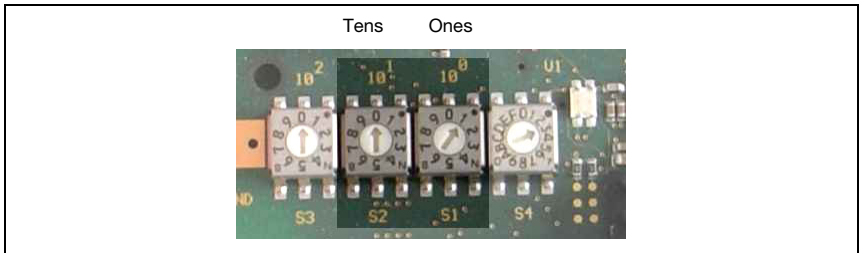

Figure 3.2: Rotary switch for setting the address

Set CANopen baud rate on the MA

The CANopen baud rate is defined for the entire network in the planning tool/control. The baud rate is set on the MA 235*i* via the baud rate selector switch. Only if the baud rates are the same is communication with the MA 235*i* possible.

↳ Set the baud rate of the gateway via the **S3** rotary switch to the value defined in the control.

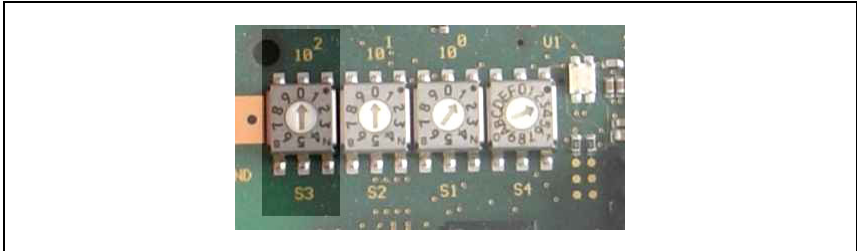

Figure 3.3: Rotary switch for setting baud rate

Switch position	Baud rate [kBd]
0	auto
1	10
2	20
3	50
4	100
5	125
6	250
7	500
8	800
9	1000

↳ Finally, close the housing of the MA 235*i*.



Attention!

Only then may the supply voltage be applied.

Upon startup of the MA 235*i*, the device selection switch is queried and the gateway automatically sets itself to the Leuze device.

Connecting functional earth FE

↳ Ensure that the functional earth (FE) is connected correctly.

Unimpaired operation is only guaranteed when the functional earth is connected properly. All electrical disturbances (EMC couplings) are discharged via the functional earth connection.

3.3.2 Connecting the power supply and the bus cable

- ↳ Ideally, use the ready-made cables listed in chapter 14.5.3 to connect the gateway to the power supply via the **PWR IN** connection.
- ↳ The ready-made cables listed in chapter 14.6.4 are preferred for connecting the gateway to the fieldbus via the **HOST / BUS IN** connection.
- ↳ If applicable, use the **BUS OUT** connection if you would like to construct a network with linear topology.

3.4 Starting the device

- ↳ Apply the supply voltage +18 ... 30VDC (typ. +24VDC); the MA 235*i* starts up. The PWR LED displays that it is ready for operation.

3.5 MA 235*i* on the CANopen

- ↳ Install the EDS file corresponding to the MA 235*i* in your planning tool/the control.



Notice!

You can find the EDS file at: www.leuze.com

The MA 235*i* is configured in the planning tool/control by means of the EDS file. The MA 235*i* is assigned an address in the planning tool, which then has to be set in the MA 235*i* via the S1 and S2 address switches. Only if the addresses are the same between the MA 235*i* and the control can communication be established.

After all parameters have been set in the planning tool/control, the download to the MA 235*i* takes place. The set parameters are now stored on the MA 235*i*.

Afterwards, all MA 235*i* parameters should be stored via upload in the control. This aids in retaining the parameters during device exchanges, as they are now also stored centrally in the control.

The CANopen baud rate is defined for the entire network in the planning tool/control. The baud rate is set on the MA 235*i* via the S3 baud rate selector switch.

Only if the baud rates are the same is communication with the MA 235*i* possible.

Detailed information can be found in chapter 12.

4 Device description

4.1 General Information to the connector units

The modular interfacing unit of the MA 2xx*i* family is a versatile gateway for integrating Leuze RS 232 devices (e.g., BCL 22 bar code readers, RFID devices, RFM 32, ...) into the respective fieldbus. The MA 2xx*i* gateways are intended for use in industrial environments with a high protection class. Various device versions are available for the conventional fieldbuses. With a stored parameter structure for the connectable RS 232 devices, commissioning could hardly be simpler.

4.2 Characteristics of the connector units

A special characteristic of the MA 235*i* device family are three function modes:

1. **Transparent mode**

In this function mode, the MA 235*i* functions as a pure gateway with automatic communication from and to the PLC. Absolutely no special programming by the user is necessary for this purpose. The data is not buffered or stored temporarily, however. Instead, it is "passed on".

The programmer must make certain to retrieve the data from the input memory of the PLC at the right time, as it is otherwise overwritten by new data.

2. **Collective mode**

In this operating mode, data and telegram parts are temporarily stored in the memory (buffer) of the MA and sent to the RS 232 interface or to the PLC in a telegram by means of bit activation. In this mode, however, all communication control must be programmed on the PLC.

This function mode is helpful, for example, for very long telegrams or when one or more codes with long code lengths are read.

3. **Command mode**

With this special operating mode, it is possible to use the first bytes of the data range to transmit predefined commands to the connected device by means of bit activation. For this purpose, device-dependent commands (so-called online commands) are predefined via the device selection switch, see chapter 16 "Specifications for Leuze end devices".

4.3 Device construction

The MA 235*i* modular interfacing unit is used for interconnecting Leuze devices, such as the BCL 8, BCL 22, etc., directly to the fieldbus. This is accomplished by transmitting the data from the Leuze device via an RS 232 (V.24) interface to the MA 235*i* where a module converts it into the fieldbus format. The data format of the RS 232 interface corresponds to the standard Leuze data format.

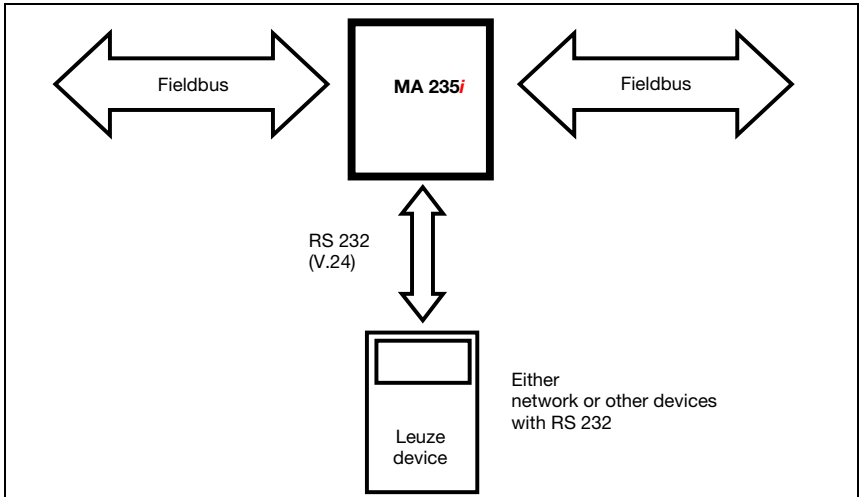

Figure 4.1: Connection of a Leuze device (BCL, RFI, RFM, ...) to the fieldbus

The cable of the respective Leuze device is guided through cable bushings with PG cable glands into the MA 235*i* and connected there with the PCB connectors.

The MA 235*i* is intended as a gateway for any RS 232 devices, e.g., BCL 300i, hand-held scanners, scales or for coupling a multiNet network.

The RS 232 cables are internally connectable using JST plug connectors. The cable can be connected to the device using a stable PG cable gland which provide strain relief and protection against contamination.

With the help of adapter cables with Sub-D 9 or open cable end, other RS 232 devices can also be connected.

4.4 Operating modes

For fast commissioning, the MA 235*i* offers an additional operating mode, the "Service mode", in addition to the "Standard mode". In this operating mode, the Leuze device can, for example, be configured on the MA 235*i* and the network settings of the MA can be displayed. To do this, you need a PC/laptop with a suitable terminal program, as BCL-Config from Leuze or similar.

Service switch

Select between "operation" and "service" modes with the service switch. You have the following options:

Pos. RUN:

Operation

The Leuze device is connected to the fieldbus and communicates with the PLC.

Pos. DEV:

Service Leuze device

The connection between the Leuze device and the fieldbus is interrupted. With this switch position, you can communicate directly with the Leuze device at the fieldbus gateway via RS 232. You can send online commands via the service interface, configure the Leuze device using the corresponding BCL- BPS-, ...-Config configuration software and have the read data of the Leuze device output.

Pos. MA:

Service fieldbus gateway

With this switch setting, your PC/terminal is connected with the fieldbus gateway. In doing so, the current setting values of the MA (e.g. address, RS 232 parameters) can be called up via a command.

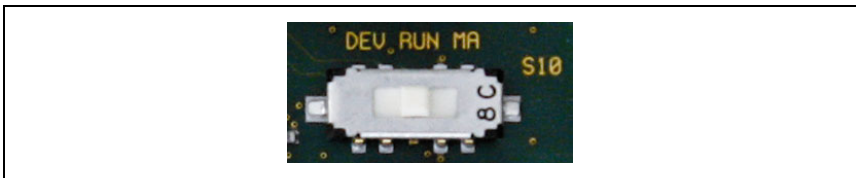

Figure 4.2: Service-switch switch positions



Notice!

If the service switch is on one of the service settings, the CAN LED flashes on the front side of the device, see chapter 8.1.2 "LED indicators on the housing".

Furthermore, on the control, the SMA service bit of the status bytes signals that the MA is in service mode.

Service interface

The service interface can be accessed once the MA 235*i* housing cover has been removed and features a 9-pin Sub-D connector (male). A crossed RS 232 connection cable is required to make the Rx/D, Tx/D and GND connections.

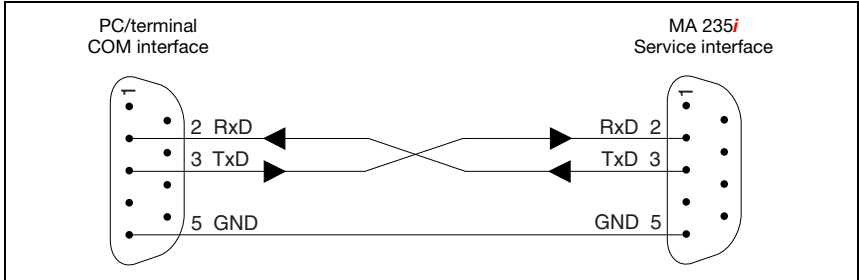

Figure 4.3: Connecting the service interface to a PC/terminal



Attention!

For the service PC to function, the RS 232 parameters must be the same as those of the MA. The Leuze standard setting of the interface is 9600bd, 8N1 and STX, data, CR, LF.

4.5 Fieldbus systems

Various product variants of the MA 2xx*i* series are available for connecting to different fieldbus systems such as PROFIBUS DP, PROFINET-IO, DeviceNet, CANopen and Ethernet or EtherCAT.

4.5.1 CANopen

General information on CANopen

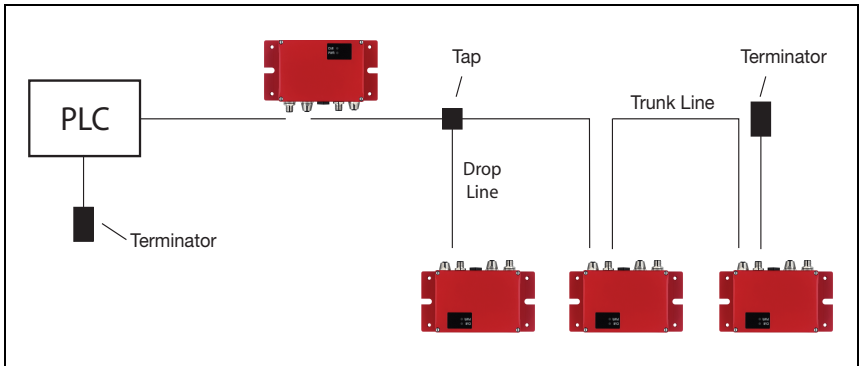

Figure 4.4: Bus topology

The CAN bus is a serial 2-wire bus system to which all participants are connected in parallel (i.e., using short stub cables). To avoid reflections, the bus must be terminated with a terminating resistor of 120ohm at each end of the trunk line. Terminating resistors are also required for very short trunk line cable lengths.

If the MA 235*i* is the last participant in the trunk line, the trunk line can be terminated via the M12 bus OUT connection. For this purpose, Leuze electronic offers an M12 terminating resistor, see chapter 14 "Type overview and accessories".

Bus line (trunk line)

For CAN, the maximum cable length of the trunk line is predominantly limited by the signal propagation time. The multi-master bus-access process (arbitration) requires that the signals are present virtually simultaneously at all nodes/participants. Therefore, the cable length of the trunk cable must be adapted to the baud rate.

Baud rate	Bus length
1 Mbit/s	< 20m
800kbit/s	< 50m
500kbit/s	< 100m
250kbit/s	< 250m
125kbit/s	< 500m
50kbit/s	< 1000m
20kbit/s	< 2500m

Stub cables (drop lines)

If possible, stub cables should be avoided because they cause signal reflections as a matter of principle. Generally, the reflections caused by stub cables are not critical, however, if the following stub cable lengths are not exceeded.

Baud rate	Length of stub cables	Total length of all stub cables
1 Mbit/s	< 1m	< 5m
800kbit/s	< 1m	< 25m
500kbit/s	< 1m	< 25m
250kbit/s	< 10m	< 50m
125kbit/s	< 20m	< 100m
50kbit/s	< 50m	< 250m
20kbit/s	< 50m	< 250m



Attention!

*Stub cables must not be fitted with terminating resistors. If the MA 235*i* is integrated into a stub cable, the M12 bus OUT connection must not be terminated.*

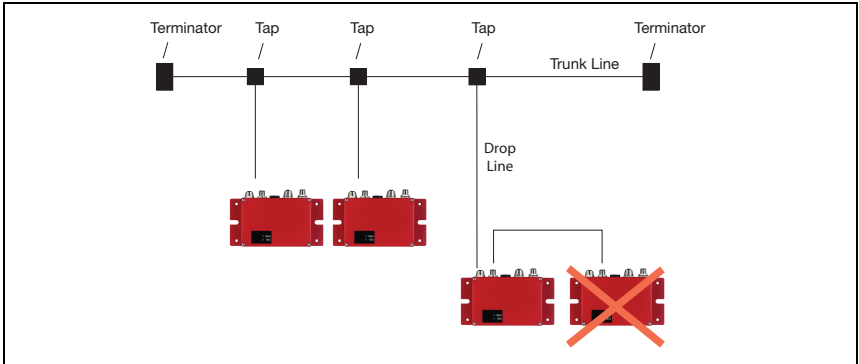

Figure 4.5: Prohibited networking within a stub cable



Attention!

MA 235*i* should not be networked with each other within a stub cable. The max. permissible cable length of a stub cable must not be exceeded. Taps and multi-taps permit a wide range of topologies.

Address assignment



Notice!

The participant-specific address for CANopen is also called the Node ID. Throughout this handbook, the term "address" is used, which is identical to "Node ID".

Each participant connected to CANopen is assigned its own address (Node ID). Up to 127 participants can be connected to one network. The addresses of the MA range from 1 to 99. The address 0 is usually reserved for the CANopen master.



Notice

*The "Layer Setting Services (LSS)" function is not supported by the MA 235*i*. For this reason, the address must be set manually. See "Switch for address selection in the fieldbus" on page 40.*

Baud rate setting

The MA 235*i* supports the following baud rates:

- 1 Mbit/s
- 800kbit/s
- 500kbit/s
- 250kbit/s
- 125kbit/s
- 100kbit/s
- 50kbit/s
- 20kbit/s
- 10kbit/s

The default setting of the gateway is "auto".



Notice

*The "Layer Setting Services (LSS)" function is not supported by the MA 235*i*. The baud rate must be set manually. See "Switch for setting the baud rate" on page 40.*

5 Specifications

5.1 General specifications

Electrical data

Interface type 1	CANopen, integrated switch, BUS: 1x M12 connector (A-coded), 1x M12 socket (A-coded) PWR/IO: 1x M12 connector (A-coded), 1x M12 socket (A-coded)
Interface type 2	RS 232
Service interface	RS 232, 9-pin Sub-D connector, Leuze standard
data format	Data bit: 8, parity: None, stop bit: 1
Switching input/output	1 switching input/1 switching output device-dependent voltage
Operating voltage	18 ... 30VDC (PELV, Class 2) ¹⁾
Power consumption	Max. 5VA (without DEV, current consumption max. 300mA)
Max stress on the connector (PWR IN/OUT)	3A
Hand-held scanner operating voltage	4.75 ... 5.25VDC / max. 1 A

Indicators

CAN LED	green	Bus state ok
	red	Bus error
PWR LED	green	Power
	red	Collection error

Mechanical data

Protection class	IP 65 (with screwed-on M12 and connected Leuze device)
Weight	700 g
Dimensions (HxWxD)	130 x 90 x 41 mm / with plate: 180 x 108 x 41 mm
Housing	Diecast aluminum
Connection	2 x M12: BUS IN / BUS OUT CANopen 1 connector: RS 232 1 x M12: Power IN/GND and switching input/output 1 x M12: Power OUT/GND and switching input/output

Environmental data

Operating temperature range	0°C ... +55°C
Storage temperature range	-20°C ... +60°C
Air humidity	Max. 90% rel. humidity, non-condensing
Vibration	IEC 60068-2-6, test FC

Shock	IEC 60068-2-27, test Ea
Electromagnetic compatibility	EN 61000-6-3:2007 (interference emissions for residential, commercial and light-industrial environments) EN 61000-6-2:2005 (interference rejection for industrial sectors)
Certifications	UL 60950-1, CSA C22.2 No. 60950-1 ¹⁾

1) For UL applications: only for use in "Class 2" circuits acc. to NEC.

5.2 Dimensioned drawings

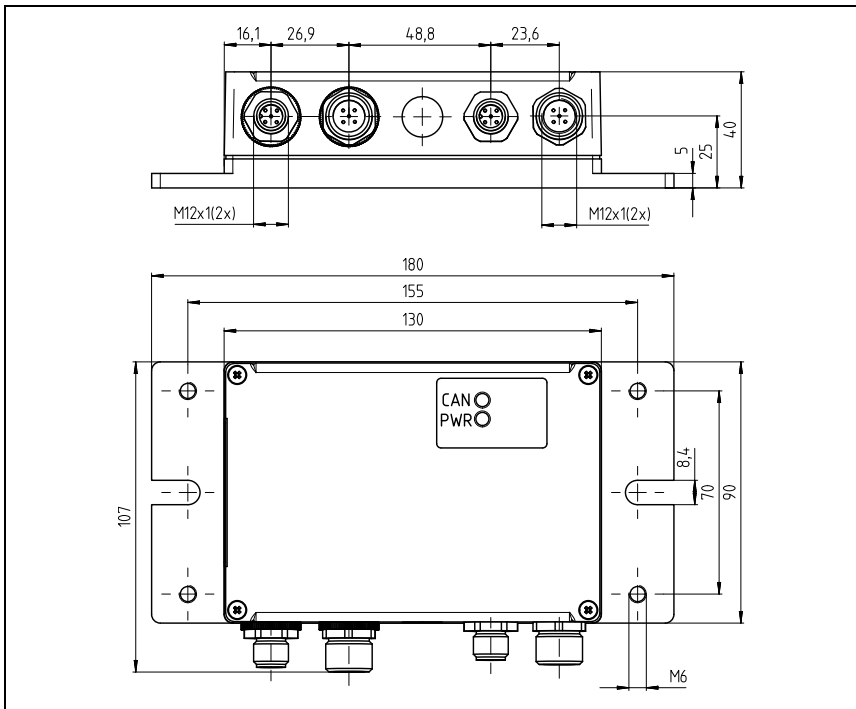

Figure 5.1: MA 235*i* dimensioned drawing

5.3 Type overview

The following versions of the MA 2xx*i* gateway family are available for facilitating the integration of Leuze RS 232 devices in the various fieldbus types.

Fieldbus	Device type	Part no.
PROFIBUS DP V0	MA 204 <i>i</i>	50112893
Ethernet TCP/IP	MA 208 <i>i</i>	50112892
PROFINET-IO RT	MA 248 <i>i</i>	50112891
DeviceNet	MA 255 <i>i</i>	50114156
CANopen	MA 235 <i>i</i>	50114154
EtherCAT	MA 238 <i>i</i>	50114155
EtherNet/IP	MA 258 <i>i</i>	50114157

Table 5.1: Type overview MA 2xx*i*

6 Installation and mounting

6.1 Storage, transportation



Attention!

When transporting or storing, package the device so that it is protected against collision and humidity. Optimal protection is achieved when using the original packaging. Heed the required environmental conditions specified in the technical data.

Unpacking

- ↳ Check the packaging for any damage. If damage is found, notify the post office or shipping agent as well as the supplier.
- ↳ Check the delivery contents using your order and the delivery papers:
 - Delivered quantity
 - Device type and model as indicated on the name plate
 - Brief manual

The name plate provides information as to what MA 2xx*i* type your device is. For specific information, please refer to the package insert or chapter 14.2.

Name plate of the connector unit

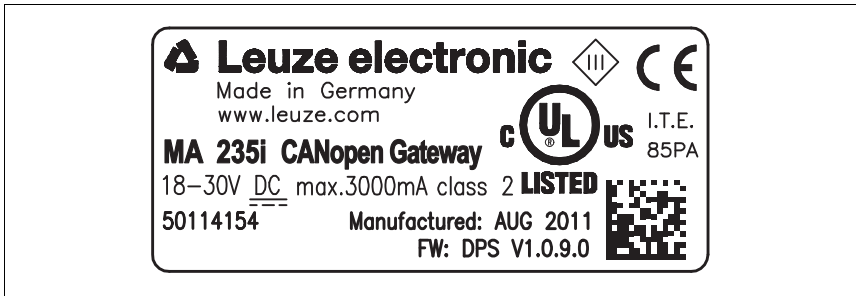

Figure 6.1: MA 235*i* device name plate

- ↳ Save the original packaging for later storage or shipping.

If you have any questions concerning your shipment, please contact your supplier or your local Leuze electronic sales office.

- ↳ Observe the applicable local regulations when disposing of the packaging materials.

6.2 Mounting

The gateway mounting plate MA 235*i* can be mounted in two different ways:

- using four threaded holes (M6) or
- using two M8 screws on the two lateral grooves.

Fastening by means of four M6 or two M8 screws



Figure 6.2: Fastening options

6.3 Device arrangement

Ideally, the MA 235*i* should be mounted so that it is easily accessible near the Ident device in order to ensure good operability - e.g., for configuring the connected device.

6.3.1 Selecting a mounting location

In order to select the right mounting location, several factors must be considered:

- The permissible cable lengths between the MA 235*i* and the host system depending on which interface is used.
- The housing cover should be easily accessible, so that the internal interfaces (device interface for connecting the Leuze device via PCB connectors, service interface) and other operational controls are easy to reach.
- Maintaining the required environmental conditions (temperature, humidity).
- Lowest possible chance of damage to the MA 235*i* by mechanical collision or jammed parts.

6.4 Cleaning

 Clean the housing of the MA 235*i* with a soft cloth after mounting. Remove all packaging remains, e.g. carton fibers or Styrofoam balls.



Attention!

Do not use aggressive cleaning agents such as thinner or acetone for cleaning the device.

7 Electrical connection

The fieldbus gateways MA 2xx*i* are connected using differently-coded M12 connectors. An RS 232 device interface allows the respective devices to be connected with system connectors. The device cables are equipped with a prefabricated PG cable gland. Coding varies and the design is implemented as either socket or connector depending on the HOST (fieldbus) interface and function. For the exact design, refer to the corresponding description of the MA 2xx*i* device type.



Notice!

The corresponding mating connectors and ready-made cables are available as accessories for all cables. For further information, see chapter 14 "Type overview and accessories".



Figure 7.1: Location of the electrical connections

7.1 Safety notices for the electrical connection



Attention!

Before connecting the device please ensure that the supply voltage matches the value printed on the nameplate. Connection of the device and cleaning must only be carried out by a qualified electrician. Ensure that the functional earth (FE) is connected correctly. Unimpaired operation is only guaranteed when the functional earth is connected properly. If faults cannot be corrected, the device should be removed from operation and protected against possible commissioning.



Attention!

For UL applications, use is only permitted in class 2 circuits in accordance with the NEC (National Electric Code).



The fieldbus gateways are designed in accordance with safety class III for supply by PELV (protective extra-low voltage with reliable disconnection).



Notice!

Protection class IP65 is achieved only if the connectors and caps are screwed into place!

7.2 Electrical connection

The MA 235*i* features two M12 connectors/sockets for voltage supply; each is A-coded.

The voltage supply (**PWR IN**) as well as the switching inputs/outputs (**PWR OUT** or **PWR IN**) are connected there. The number and function of the switching inputs/outputs is dependent on the connected end device. Two additional M12 connectors/sockets are used for connection to the fieldbus. Both of these connections are A-coded.

An internal RS 232 interface is used for connecting the respective Leuze device. Another internal RS 232 interface functions as a service interface for configuring the connected device via a serial null modem cable.

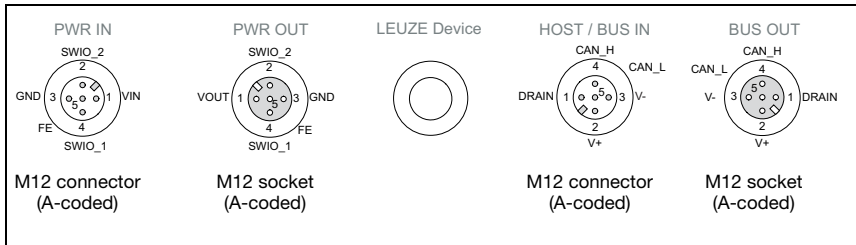

Figure 7.2: MA 235*i* connections

Described in detail in the following are the individual connections and pin assignments.



Attention!

Voltage supply and bus cable are coded in the same way. Please observe the printed connection designations

7.2.1 PWR IN – voltage supply / switching input/output

PWR IN (5-pin connector, A-coded)			
	Pin	Name	Remark
	1	VIN	Positive supply voltage +18 ... +30VDC
	2	SWIO_2	Switching input/switching output 2
	3	GND	Negative supply voltage 0VDC
	4	SWIO_1	Switching input/switching output 1
	5	FE	Functional earth
	Thread	FE	Functional earth (housing)

Table 7.1: PWR IN pin assignment



Notice!

The designation and function of the SWIO depends on the connected device. Please observe the following table!

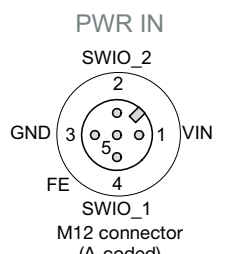
Device	PIN 2	PIN 4
BCL 22	SWOUT_1	SWIN_1
BCL 8	SW_0	SW_I
Hand-held scanner/BCL 90	n.c.	n.c.
RFM/RFU/RFI	SWOUT_1	SWIN_1
LSIS 122, LSIS 222, DCR 202i	SWOUT	SWIN
LSIS 4x2/BCL 300, BCL 500, BCL 600i	configurable IO 1 / SWIO 3 IO 2 / SWIO 4	configurable
KONTURflex	n.c.	n.c.
ODSL 9, ODSL 96B	Q1	n.c.
ODSL 30	Q1	active/reference (on SWIN_1, PWRIN)

Table 7.1: Device-specific function of the SWIOs

Supply voltage



Attention!

For UL applications, use is only permitted in class 2 circuits in accordance with the NEC (National Electric Code).



The fieldbus gateways are designed in accordance with safety class III for supply by PELV (protective extra-low voltage with reliable disconnection).

Connecting functional earth FE



Notice!

Ensure that the functional earth (FE) is connected correctly. Unimpaired operation is only guaranteed when the functional earth is connected properly. All electrical disturbances (EMC couplings) are discharged via the functional earth connection.

Switching input/output

The MA 235*i* is equipped with the **SWIO_1** and **SWIO_2** switching inputs/outputs. This is located on the PWR IN M12 connector and on the PWR OUT M12 connector. The connection of the switching inputs/outputs from PWR IN to PWR OUT can be interrupted by means of a jumper. In this case, only the switching input and output on PWR IN are active.

The function of the switching inputs and outputs is dependent on the connected Leuze device. Detailed information on this topic can be found in the respective operating instructions.

7.2.2 PWR OUT switching input/output

PWR OUT (5-pin socket, A-coded)			
	Pin	Name	Remark
	1	VOUT	Voltage supply for additional devices (VOUT identical to VIN at PWR IN)
	2	SWIO_2	Switching input/switching output 2
	3	GND	GND
	4	SWIO_1	Switching input/switching output 1
	5	FE	Functional earth
	Thread	FE	Functional earth (housing)

Table 7.2: PWR OUT pin assignment



Notice!

The maximum admissible current of the PWR OUT and IN connectors is maximum 3A. To be subtracted from this is the current consumption of both the MA and of the connected end device.

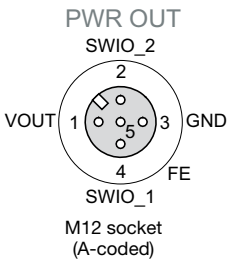
The function of the switching inputs and outputs is dependent on the connected Leuze device. Detailed information on this topic can be found in the respective operating instructions.

On delivery, the SWIO 1/2 are connected in parallel on PWR IN/OUT. This connection can be separated with a jumper.

7.3 BUS IN

The MA 235*i* makes a CANopen interface available as host interface.

BUS IN (5-pin plug, A-coded)			
	Pin	Name	Remark
	1	Drain	Shield
	2	V+	Supply voltage data V+
	3	V-	Supply voltage data V-
	4	CAN_H	Data signal CAN_H
	5	CAN_L	Data signal CAN_L
	Thread	FE	Functional earth (housing)

Table 7.3: Pin assignment HOST / BUS IN

↳ For the host connection of the MA 235*i*, the ready-made "KB DN/CAN-xxxxx-Bx" cables are preferred, see table 14.5 Bus connection cable for the MA 235ion page 77.

7.4 BUS OUT

BUS OUT (5-pin socket, A-coded)			
 <p>BUS OUT</p> <p>M12 socket (A-coded)</p>	Pin	Name	Remark
	1	Drain	Shield
	2	V+	Supply voltage data V+
	3	V-	Supply voltage data V-
	4	CAN_H	Data signal CAN_H
	5	CAN_L	Data signal CAN_L
	Thread	FE	Functional earth (housing)

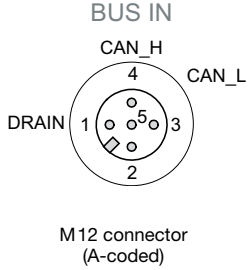
Table 7.4: Pin assignment HOST/BUS OUT

↳ For the host connection of the MA 235*i*, the ready-made "KB DN/CAN-xxxxx-Bx" cables are preferred, see table 14.5 Bus connection cable for the MA 235ion page 77.

If you use user-configurable cables, note the following:

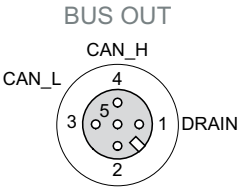

Notice!

Ensure adequate shielding. For the devices and ready-made cables offered by Leuze electronic, the shield is on PIN 1.

7.4.1 Termination of the CANopen bus

If the gateway is the last physical CANopen participant in the trunk line, it must be terminated with a terminating resistor (see "Accessory terminating resistor" on page 74).



Notice!

Stub cables must not be fitted with terminating resistors. If the MA 235*i* is integrated into a stub cable, the BUS OUT connection must not be terminated.

7.5 Device interfaces

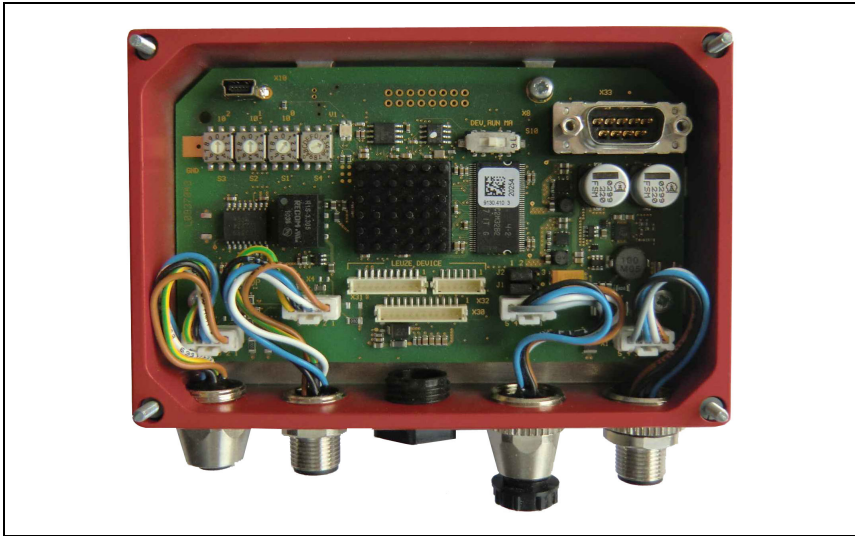

Figure 7.3: Open the MA 235*i*

7.5.1 RS 232 device interface (accessible after opening the device, internal)

The device interface is prepared for the system plugs (PCB connectors) for Leuze devices RFI xx, RFM xx, BCL 22.

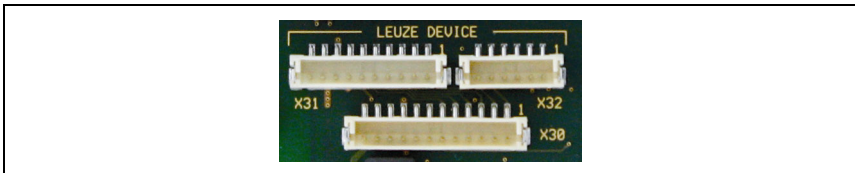

Figure 7.4: RS 232 device interface

The standard devices are connected with 6- or 10-pin connector piece to X31 or X32, respectively. For hand-held scanners, BCL 8 and BPS 8 with 5VDC $\pm 10\%$ supply (from the MA) on pin 9, the 12-pin X30 PCB connection is available as well.

By using an additional cable (cf. "Type overview and accessories" on page 74), the system connection can be established on M12 or 9-pin Sub-D, e.g., for hand-held scanners.



Notice!

When using third-party devices, check the pin assignment and voltage without fail.

7.5.2 Service interface (internal)

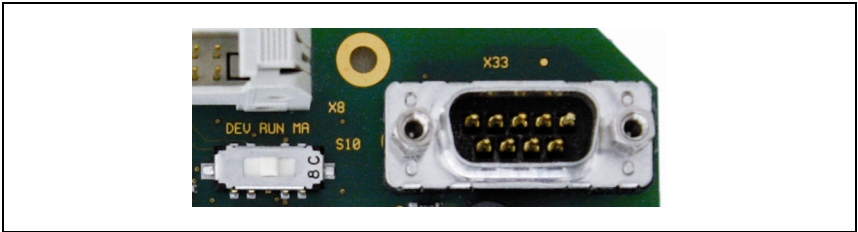

Figure 7.5: RS 232 service switch and service interface

Following activation, this interface enables access via the RS 232 to the connected Leuze device and the MA for configuration using the 9-pin Sub-D. The connection between the fieldbus interface and the device interface is switched off during access. The fieldbus itself is, however, not interrupted as a result.

The service interface can be accessed once the MA 235*i* housing cover has been removed and features a 9-pin Sub-D connector (male). A crossed RS 232 connection cable is required to make the RxD, TxD and GND connections. A hardware handshake via RTS, CTS is not supported at the service interface.

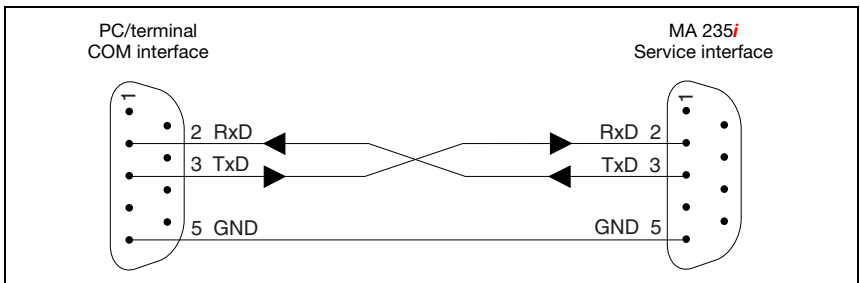

Figure 7.6: Connecting the service interface to a PC/terminal



Attention!

For the service PC to function, the RS 232 parameters must be the same as those of the MA. The Leuze standard setting of the interface is 9600Bd, 8N1 and STX, data, CR, LF.



Notice!

To configure the devices connected to the external interface, e.g., BCL 8 (JST plug connector "X30"), a cable specially configured for this purpose is necessary. The service switch must be in the "DEV" or "MA" position (Service Leuze device/MA).

8 Status displays and operational controls







Figure 8.1: LED indicators on the MA 235*i*

8.1 LED status indicators





8.1.1 LED indicators on the circuit board

LED (Status)



	off	Device OFF - no operating voltage or device defect
	continuous green light	Device ok - readiness for operation
	continuous orange light	Device error / firmware available
	flashing green-orange	Device in boot mode - no firmware

8.1.2 LED indicators on the housing

PWR LED

PWR 	off	Device OFF - no operating voltage or device error
PWR 	continuous green light	Device ok - self test successfully finished - ready
PWR 	flashing green	Device ok, device in service mode
PWR 	flashing red	Configuration error - baud rate or address incorrect

CAN LED

CAN 	continuous green light	Bus operation ok - network mode ok - connection and communication to the host established
CAN 	continuous red light	Configuration error - network error - no connection established - no communication possible

8.2 Internal interfaces and operational controls

8.2.1 Overview of operational controls of the

The operational controls of the MA 235*i* are described in the following. The figure shows the MA 235*i* with opened housing cover.

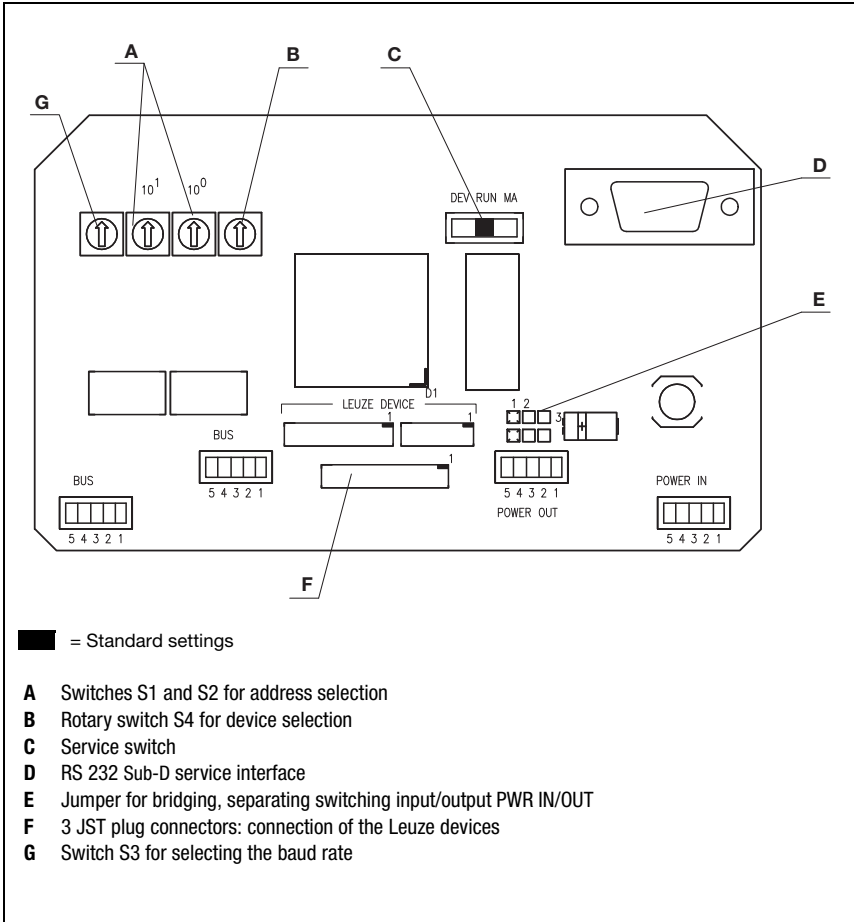

Figure 8.2: Front view: operational controls of the MA 235*i*

Circuit board element desig.	Function
X1 Operating voltage	PWR IN M12 connector for operating voltage (18 ... 30VDC) MA 235 <i>f</i> and connected Leuze device xx
X2 Output voltage	PWR OUT M12 connector for other devices (MA, BCL, sensor, ...) VOUT = VIN max. 3A
X4 HOST interface	BUS IN HOST interface for connecting to the fieldbus
X5 HOST interface	BUS OUT Second BUS interface for creating a network with other participants in a linear topology
X30 Leuze device	JST plug connector with 12 pins Connection of the Leuze devices with 4.75 ... 5.25VDC / 1 A (BCL 8, BPS 8 and hand-held scanner)
X31 Leuze device	JST plug connector with 10 pins Connection of the Leuze devices (BCL, RFI, RFM,...) Pin VINBCL with standard setting = V+ (18 - 30V)
X32 Leuze device	JST plug connector with 6 pins Connection of the Leuze devices (BCL, RFI, RFM,...) Pin VINBCL with standard setting = V+ (18 - 30V)
X33 RS 232 service interface	9-pin SUB-D connector RS 232 interface for service/setup operation. Enables the connection of a PC via serial null modem cable for configuring the Leuze device and the MA 235 <i>f</i> .
S4 Rotary switch	Rotary switch (0 ... F) for device selection Standard setting = 0
S10 DIP switch	Service switch Switch between service Leuze device (DEV), service fieldbus gateway (MA) and operation (RUN). Standard setting = operation.
J1, J2 Jumper	Bridging, separating switching input/output (interruption of connection between the two PWR M12 connectors of the SWIO 1 or SWIO 2)
S1 Rotary switch	Rotary switch (0 ... 9) for address selection 10 [^] 0 Standard setting: position 0
S2 Rotary switch	Rotary switch (0 ... 9) for address selection 10 [^] 1 Standard setting: position 0
S3 Rotary switch	Baud rate selector switch pos 0-9 (auto, 10/20/50/100/125/250/500/800/1000kBd) Default setting = pos 0 (auto)

8.2.2 Connector X30 ... connectors

PCB connectors **X30 ... X32** are available in the MA 235*i* for connecting the respective Leuze devices via RS 232.

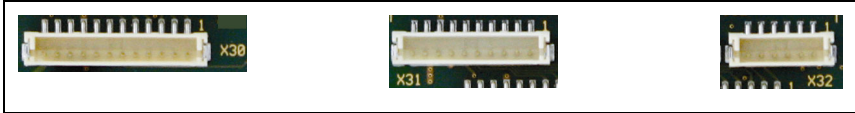

Figure 8.3: Connections for Leuze devices



Attention!

Several Leuze devices may not be connected to the MA 235*i* simultaneously, as only one RS 232 interface can be operated.

8.2.3 RS 232 service interface – X33

The **X33** RS 232 interface facilitates the configuration of the Leuze device and the MA 235*i* via PC, which is connected by means of a serial null modem cable.

X33 pin assignment – service connector

SERVICE (9-pin SUB-D connector)			
	Pin	Name	Remark
	2	RXD	Receive Data
	3	TXD	Transmit Data
	5	GND	Functional earth

Table 8.1: SERVICE pin assignment

8.2.4 S10 service switch

The **S10** DIP switch can be used to select between the "operation" and "service" modes, i.e. you switch between the following options here:

- Operation (RUN) = default setting
- Service Leuze device (DEV) and
- Service fieldbus gateway (MA)

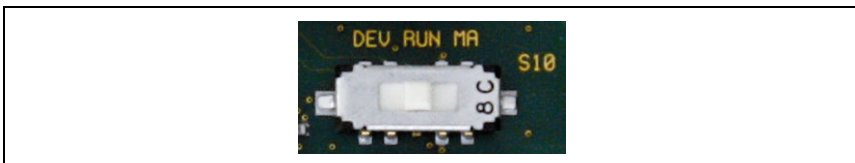

Figure 8.4: DIP switch service - operation

For further information on the corresponding options, see chapter 4.4 "Operating modes".

8.2.5 Rotary switch S4 for device selection

The **S4** rotary switch is used to select the Leuze end device.



Figure 8.5: Rotary switch for device selection

The following switch positions are assigned to the Leuze devices:

Leuze device	Switch position
Standard setting	
Other RS 232 devices such as KONTURflex QUATTRO	0
BCL 8	1
BCL 22	2
n.c.	3
BCL 300i, BCL 500i, BCL 600i	4
BCL 90, BCL 900i	5
LSIS 122, LSIS 222	6

Leuze device	Switch position
LSIS 4x2i, DCR 202i	7
Hand scanner	8
RFID (RFI xx, RFM xx, RFU xx)	9
BPS 8	A
ODS 9, ODSL 30, ODSL 96B, BPS 300i	B
MA 3x	C
Reset to factory setting	F

The gateway is set via the switch position on the Leuze device. If the switch position is changed, the device must be restarted, since the switch position is only queried after switching off completely and then restarting the device.



Notice!

In switch position "0", a distance of >20ms must be maintained between two telegrams so they can be distinguished from one another.

The parameters of the Leuze end devices are described in chapter 16.

8.2.6 Switch for address selection in the fieldbus

The gateway features the **S1** and **S2** rotary switches (ones and tens digits) for setting the station address.

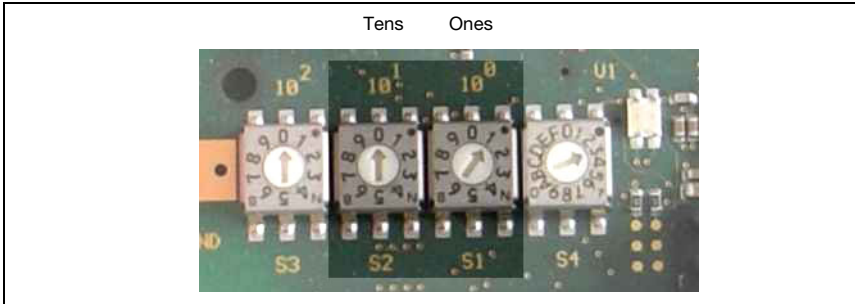

Figure 8.6: Rotary switch for setting the address

Further information on the respective address ranges and the addressing procedure can be found in chapter 12.1.

8.2.7 Switch for setting the baud rate

You can set the baud rate for data transmission with the **S3** rotary switch.

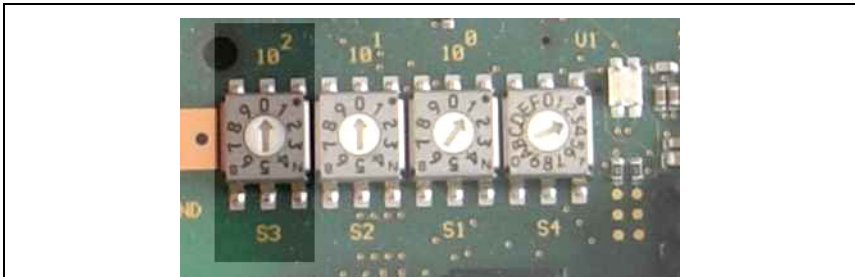

Figure 8.7: Rotary switch for setting baud rate

Switch position	Baud rate [kBd]
0	auto
1	10
2	20
3	50
4	100
5	125
6	250
7	500
8	800
9	1000

9 Configuration

The MA 235*i* is configured using the EDS file via the device manager of the control. The connected device is normally configured via the service interface of the MA with the help of a suitable configuration program.

The respective configuration programs – e.g. for bar code readers the BCL-Config, for RFID devices the RF-Config etc. – and the associated documentation are provided on the Leuze home page www.leuze.com.

**Notice!**

In order to display the help texts, a PDF viewer program (not included in the delivery contents) must also be installed. For important information on configuring and on the configurable functions, please refer to the description of the respective device.

**Notice!**

*The size of the input and output data is permanently set for CANopen: the MA 235*i* always provides the process data for transmission in this form: 8 bytes Tx and 8 bytes Rx.*

9.1 Connecting the service interface

The RS 232 service interface is connected after opening the device cover of the MA 235*i* via the 9-pin Sub-D and a cross-wired null modem cable (RxD/TXD/GND). For connection, see chapter "Service interface (internal)" on page 33.

The service interface is activated with the help of the service switch and establishes a direct connection to the connected device with the "DEV" (Leuze device) or "MA" (gateway) setting.

9.2 Reading out information in Service mode

↳ *After starting up in the "RUN" switch position, set the service switch of the MA to the "MA" position.*

↳ *Now start one of the following terminal programs: e.g., BCL, RF, BPS Config.*

Alternatively, you can also use the Windows tool "Hyperterminal".

↳ *Start the program.*

↳ *Select the correct COM port (e.g., COM1) and set the interface as follows:*

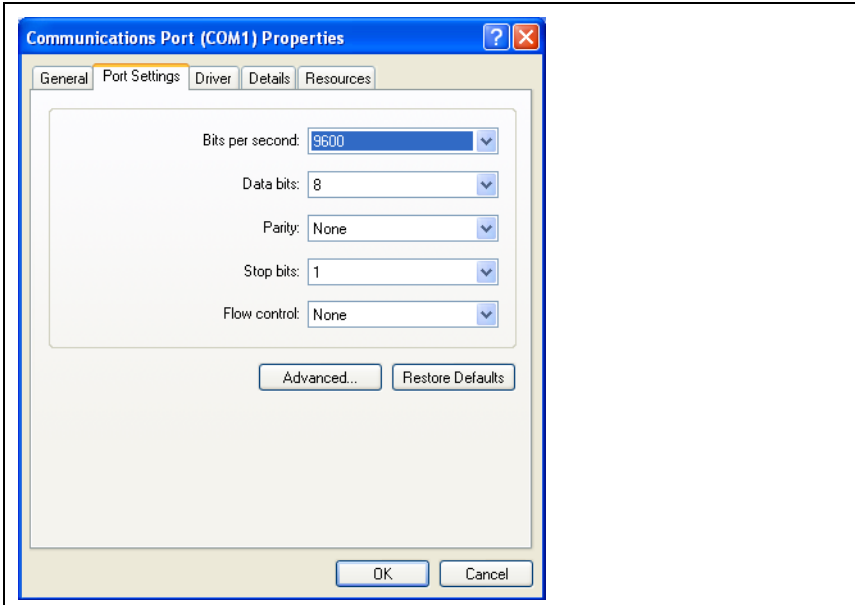

Figure 9.1: COM port settings



Notice!

Observe that *STX*, *data*, *CR*, *LF* framing must be set on the PC terminal program so that communication is possible with the connected Leuze device.

Commands

You can now call up information on the MA 235*i* by sending the following commands.

v	General service information.
s	Enable memory mode for the last frames.
l	The memory mode shows the last RX and TX frames for ASCII and fieldbus.

Table 9.1: Available commands

Information

Version	Version information.
Firmware date	Firmware date.

Table 9.2: General firmware information

Selected scanner	Currently selected Leuze device (selected via switch S4).
Gateway mode	Transparent or Collective mode.
Ring buffer fill level	Current fill level of the ring memory in Collective mode (ASCII->Fieldbus). 1024 bytes max.
Received ASCII Frames	Number of received ASCII frames.
ASCII Framing Error (GW)	Number of received framing errors.
Number of Received CTB's	Number of CTB commands.
Number of Received SFB's	Number of SFB commands.
Command-Buffer fill level	Current fill level of the ring memory in Command mode (fieldbus->ASCII). 1024 bytes max.
Number of send fieldbus frames	Number of frames sent via the fieldbus.
Number of invalid commands	Number of invalid commands.

Table 9.3: General gateway information

ND	Current status of ND bit.
Data loss	Current status of data loss bit.

Table 9.4: Current states of the status and control bits

ASCII-Start-Byte	Currently configured start byte (dependent on switch position S4).
ASCII-End-Byte1	Currently configured stop byte 1 (dependent on switch position S4).
ASCII-End-Byte2	Currently configured stop byte 2 (dependent on switch position S4).
ASCII baud rate	Currently configured baud rate (dependent on switch position S4).
ASCII warm start status	Indicates whether the ASCII memory has detected and accepted a valid configuration.

Table 9.5: ASCII configuration

Input Data length	Length of the data received (Rx, 8Byte).
Output Data length	Length of the data supplied (Tx, 8Byte).
Node ID	Participant address of the address switch.
Baud Rate[kBaud]	Set baud rate.

Table 9.6: CANopen parameters MA 235*i*

10 Telegram

10.1 Structure of the fieldbus telegram

All operations are performed by control and status bits. Two bytes of control information and two bytes of status information are available for this purpose. The control bits are a part of the output module and the status bits are a part of the input bytes. The data starts with the third byte.

If the actual data length is longer than the data length configured in the gateway, only part of the data is transmitted; the remaining data is lost. In this case, the DL (data loss) bit is set.

The following telegram structure is used between **PLC -> fieldbus gateway**:

7	6	5	4	3	2	1	0	
ND	Address 4	Address 3	Address 2	Address 1	Address 0	Broadcast	Command mode	Control byte 0
				CTB	SFB		R-ACK	Control byte 1
Data byte / parameter byte 0								Data
Data byte / parameter byte 1								
...								

This telegram structure is used between **fieldbus gateway -> PLC**:

7	6	5	4	3	2	1	0	
ND	B0	DL	BLR	DEX	SMA		W-ACK	Status byte 0
DLC7	DLC6	DLC5	DLC4	DLC3	DLC2	DLC1	DLC0	Status byte 1
Data byte / parameter byte 0								Data
Data byte / parameter byte 1								
...								

Only the data part with the corresponding frame (e.g., STX, CR & LF) is then transmitted between the fieldbus gateway and the Leuze end device. The two control bytes are processed by the fieldbus gateway.

The corresponding control and status bits and their meaning are specified in section 10.2 and section 10.3.

Further information on the broadcast control bytes and address bits 0 ... 4 can be found in chapter "Modular interfacing unit MA 3x (S4 switch position C)" on page 93.

10.2 Description of the input bytes (status bytes)

10.2.1 Structure and meaning of the input bytes (status bytes)

7	6	5	4	3	2	1	0	
ND	BO	DL	BLR	DEX	SMA		W-ACK	Status byte 0
DLC7	DLC6	DLC5	DLC4	DLC3	DLC2	DLC1	DLC0	Status byte 1
Data byte / parameter byte 0								Data
Data byte / parameter byte 1								
...								

Table 10.1: Structure of the input bytes (status bytes)

Bits of the input byte (status byte) 0

Bit no.	Designation	Meaning
0	W-ACK	Write-Acknowledge (write confirmation when using buffer)
2	SMA	Service mode active(service mode activated)
3	DEX	Data exist (data in transmit buffer)
4	BLR	Next block ready (new block ready)
5	DL	Data loss
6	BO	Buffer overflow
7	ND	New data only in Transparent mode

Bits of the input byte (status byte) 1

Bit no.	Designation	Meaning
0 ... 7	DLC0 ... DLC7	Data Length Code (length of the following user data)



Notice!

T-bit means toggle bit, i.e. this bit changes its state on each event ("0" → "1" or "1" → "0").

10.2.2 Detailed description of the bits (input byte 0)

Bit 0: Write-Acknowledge: W-ACK

This bit is only relevant for writing slave data in blocks, see chapter 11.1.2 (buffer data on RS 232). It toggles when data from the PLC are sent to the MA with CTB or SFB.

Input data	Description	Addr.	Data type	Value range	Default
W-ACK	<p>Write-Acknowledge (write confirmation) Write handshake Indicates that the data was successfully sent by the PLC to the gateway. Write-Acknowledge is indicated via this bit. The W-ACK bit is toggled by the fieldbus gateway whenever a transmit command has been successfully executed. This applies both for the transmission of data to the transmit buffer with the CTB command and for sending the transmit buffer contents with the SFB command.</p>	0.0	Bit	<p>0->1: Successfully written 1->0: Successfully written</p>	0

Bit 2: Service mode active: SMA

Input data	Description	Addr.	Data type	Value range	Default
SMA	<p>Service mode active (SMA) The SMA bit is set if the service switch is set to "MA" or "DEV", i.e. if the device is in either fieldbus gateway or Leuze device service mode. This is also indicated by a flashing PWR LED on the front side of the device. Upon changing to the normal operating mode "RUN", the bit is reset.</p>	0.2	Bit	<p>0: Device in operating mode 1: Device in service mode</p>	0h

Bit 3: Data exist: DEX

This bit is only relevant for reading slave data in Collective mode relevant, see chapter 11.1.1.

Input data	Description	Addr.	Data type	Value range	Default
DEX	<p>Data exist (data in transmit buffer) Indicates that further data is stored in the transmit buffer which is ready for transmission to the control. This flag bit is always set to high ("1") by the fieldbus gateway as long as data is in the buffer.</p>	0.3	Bit	<p>0: No data in the transmit buffer 1: Further data in the transmit buffer</p>	0h

Bit 4: Next block ready to transmit: BLR

This bit is only relevant for reading slave data in Collective mode relevant, see chapter 11.1.1.

Input data	Description	Addr.	Data type	Value range	Default
BLR	Next block ready to transmit (new block ready) The Block Ready toggle bit changes its state whenever the fieldbus gateway has removed received data from the receive buffer and registered it in the corresponding receive-data bytes. This signals to the master that the quantity of data indicated in the DLC bits to be present in the input data bytes originated in the data buffer and is current.	0.4	Bit	0->1: Data transmitted 1->0: Data transmitted	0

Bit 5: Data loss: DL

This bit is important for monitoring data transmission in Transparent and Collective mode.

Input data	Description	Addr.	Data type	Value range	Default
DL	Data loss (Data transmission monitoring) This bit is set until the device is reset (bit pattern see chapter 10.4 "RESET function / deleting memory") in case gateway data was not able to be sent to the PLC and was lost. Furthermore, this bit is set in case the configured data frame, e.g. 8 bit, should be smaller than the data to be transmitted to the PLC, e.g. bar code with 20 digits. In this case, the first 8 digits are transmitted to the PLC, the rest are truncated and are lost. In this process, the Data loss bit is also set.	0.6	Bit	0->1: Data loss	0

Bit 6: Buffer overflow: BO

This bit is only relevant in Collective mode.

Input data	Description	Addr.	Data type	Value range	Default
BO	Buffer overflow (buffer overflow) This flag bit is set to high ("1") when the buffer overflows. The bit is automatically reset when the buffer again has memory space available. While the BO bit is set, the RTS signal of the serial interface is deactivated. The memory size of the gateway for the data of both the PLC and the Leuze end device is 1 kByte.	0.6	Bit	0->1: Buffer overflow 1->0: Buffer o.k.	0

Bit 7: New data: ND

This bit is only relevant in Transparent mode.

Input data	Description	Addr.	Data type	Value range	Default
ND	New data (new data) This bit is toggled on each data set that is sent from the gateway to the PLC. This can be used to differentiate between multiple, identical data sets that are sent to the PLC.	0.7	Bit	0->1; 1->0: On each status change for new data	0

10.2.3 Detailed description of the bits (input byte 1)

Bit 0 ... 7: Data length code: DLC0 ... DLC7

Input data	Description	Addr.	Data type	Value range	Default
DLC0 ... DLC7	Data length code (number of user data in bytes) Stored in these bits is the number of user data bytes transmitted to the PLC which follow.	1.0 ... 1.7	Bit	1 _h (00001 _b) ... FF _h (00255 _d)	0h (00000b)

10.3 Description of the output bytes (control bytes)

10.3.1 Structure and meaning of the output bytes (control bytes)

7	6	5	4	3	2	1	0	
ND	Address 4	Address 3	Address 2	Address 1	Address 0	Broadcast	Command mode	Control byte 0
				CTB	SFB		R-ACK	Control byte 1
Data byte 1								Data
Data byte 2								
...								

Table 10.2: Structure of the output bytes (control bytes)

Bits of the output byte (control byte) 0

Bit no.	Designation	Meaning
0	Command mode	Command mode
1	Broadcast	Broadcast (only relevant with a connected MA 3x)
2 ... 6	Address 0 .. 4	Address bits 0 .. 4 (only relevant with a connected MA 3x)
7	ND	New data

Bits of the output byte (control byte) 1

Bit no.	Designation	Meaning
0	R-ACK	Read-Acknowledge
2	SFB	Send data from transmit buffer
3	CTB	Copy to transmit-buffer

10.3.2 Detailed description of the bits (output byte 0)

Bit 0: Command mode: Command mode

Output data	Description	Addr.	Data type	Value range	Default
Command mode	Command mode This bit is used to activate Command mode. In Command mode, no data is sent by the PLC to the Leuze end device via the gateway. In Command mode, various bits that execute corresponding commands depending on the selected Leuze device can be set in the data- or parameter field. For further information, see chapter 11.1.3 "Command mode".	0.0	Bit	0: Default, transparent data transmission 1: Command mode	0

The following two control bits ("Bit 1: Broadcast: Broadcast" on page 49 and "Bits 2 ... 6: address bits 0 .. 4: address 0 .. 4" on page 49) are only relevant with a connected MA 3x. With other devices, these fields are ignored.

Bit 1: Broadcast: Broadcast

Output data	Description	Addr.	Data type	Value range	Default
Broadcast	Broadcast A broadcast only functions with a multiNet network connected via the MA 3x. If this bit is activated, the gateway automatically adds the broadcast command "00B" before the data. This is directed at all participants in the multiNet.	0.1	Bit	0: No broadcast 1: Broadcast	0

Bits 2 ... 6: address bits 0 .. 4: address 0 .. 4

Output data	Description	Addr.	Data type	Value range	Default
Address 0..4	Address bits 0 .. 4 As with the broadcast command, individual devices in the multiNet can also be addressed via the MA 3x. In this case, the corresponding address of the device precedes the data field telegram.	0.2 ... 0.6	Bit	00000: Addr. 0 00001: Addr. 1 00010: Addr. 2 00011: Addr. 3 ...	0

Bit 7: New data: ND

Output data	Description	Addr.	Data type	Value range	Default
ND	New data This bit is needed if several identical pieces of data are to be sent in sequence.	0.7	Bit	0->1; 1->0: On each status change for new data	0

10.3.3 Detailed description of the bits (output byte 1)

Bit 0: Read-Acknowledge: R-ACK

This bit is only relevant for writing slave data in blocks (Collective mode), see chapter 11.1.2.

Output data	Description	Addr.	Data type	Value range	Default
R-ACK	Read-Acknowledge (read confirmation) Toggle bit: Indicates to the fieldbus gateway that the "old" data has been processed and that new data can be received. At the end of a read cycle, this bit must be toggled in order to be able to receive the next data set. This toggle bit is switched by the master after valid received data has been read out of the input bytes and the next datablock can be requested. If the gateway detects a signal change in the R-ACK bit, the next bytes are automatically written from the receive buffer to the input data words and the BLR bit toggled. Further toggling erases the memory (to 00h).	1.0	Bit	0->1 or 1->0: Successfully written & ready for the next transmission	0

Bit 2: Send data from buffer: SFB

This bit is only relevant for writing slave data in blocks (Collective mode), see chapter 11.1.2.

Output data	Description	Addr.	Data type	Value range	Default
SFB	Send data from buffer (send data from the gateway transmit buffer to the RS 232) Toggle bit: changing this bit causes all data which was copied to the transmit buffer of the fieldbus gateway via the CTB bit to be transmitted to the RS 232 interface or the connected Leuze device.	1.2	Bit	0->1: Data to RS 232 1->0: Data to RS 232	0

Bit 3: Copy to transmit buffer: CTB

This bit is only relevant for writing slave data in blocks (Collective mode), see chapter 11.1.2.

Output data	Description	Addr.	Data type	Value range	Default
CTB	<p>Copy to transmit buffer (transmission data to transmit buffer)</p> <p>Toggle bit: Changing this bit writes the data from the PLC to the transmit buffer of the fieldbus gateway. This is used, for example, for long command strings which must be transmitted to the connected ident device.</p> <p>The CTB toggle bit is switched whenever transmit data is not to be sent directly via the serial interface, but instead transferred to the transmit buffer.</p>	1.3	Bit	<p>0->1: Data in buffer</p> <p>1->0: Data in buffer</p>	0



Notice!

The state change of the CTB bit signals the MA that the data is going into the buffer; therefore, it's essential to observe the order!

When the CTB is not used, the telegram (which fits in one cycle) is transmitted directly to the RS 232 interface. Please make sure it is complete!

10.4 RESET function / deleting memory

For many applications, it is helpful to be able to reset the MA buffer (in Collective mode) or status bits.

The following bit pattern can be transmitted from the PLC for this purpose (if >20 ms is pending):

Control byte 0: 10101010 (AAh)
 Control byte 1: 10101010 (AAh)
 OUT data byte 0/parameter byte 0: AAh
 OUT data byte 1/parameter byte 1: AAh

This sets the memory or status/control bits to 00h.

Please observe that the data image may need to be updated by toggling in Collective mode.

11 Modes

11.1 Functionality of the data exchange

The fieldbus gateway has two different modes that can be selected via the PLC:

- **Transparent mode (standard setting)**

In Transparent mode, all data is sent 1:1 and directly by the serial end device to the PLC. It is not necessary to use status and control bits here. However, only data bytes possible for **one** transmission cycle are transmitted - all others are lost.

The distance between two successive telegrams (without frame) must be more than 20ms, since there is otherwise no clear separation between them.

ASCII characters are typically expected as data content; under certain circumstances, the MA therefore detects different control characters as invalid characters in the data range and truncates them. At 00_h in the data range, the MA cuts the telegram off because unnecessary bytes are also filled with 00_h.

- **Collective mode**

In Collective mode, the data of the serial end device is stored temporarily in the fieldbus gateway by toggling the CTB bit and is not sent to the PLC in blocks until prompted to do so by the PLC.

On the PLC, a status bit (DEX) then signals that new data is ready for retrieval. This data is then read out from the fieldbus gateway in blocks (toggle bit).

In order to distinguish between the individual telegrams on the PLC, in Collective mode the serial frame is sent to the PLC in addition to the data.

The size of the buffer is 1 kByte.



Notice!

In Collective mode, the CTB and SFB bits are needed for communication handling via the buffer. Telegrams that can also be completely transmitted in one cycle in Collective mode (including data frame) go directly through. If PLC data is provided and transferred without a state change of the CTB bit, it goes directly to the RS 232 interface with the set telegram data length. Incomplete (incl. data frame) or faulty telegrams can cause error messages in the connected device!

Combination with the Command mode is possible.

Data exchange in blocks must be programmed on the PLC.

11.1.1 Reading slave data in Collective mode (gateway -> PLC)

If the Leuze device transmits data to the fieldbus gateway, the data is stored temporarily in a buffer. The PLC is signaled via the "DEX" bit that data is ready for retrieval in the memory. Data is not automatically transmitted.

If no further user data is present in the MA 235*i* ("DEX" bit = "0"), the "R-ACK" bit must be toggled once as read confirmation to release data transmission for the next read cycle.

If the buffer still contains more data ("DEX" bit = "1"), the next remaining user data present in the buffer is transmitted by toggling the "R-ACK" control bit. This process is to be repeated until the "DEX" bit returns to "0"; all data has then been removed from the buffer. "R-ACK" must be toggled here again once more as a terminating read confirmation in order to release data transmission for the next read cycle.

Used status and control bits:

- DLC
- BLR
- DEX
- R-ACK

11.1.2 Writing slave data in Collective mode (PLC -> gateway)

Writing in blocks

The data sent by the master to the slave is first collected in a "transmit buffer" by setting the "CTB" bit (**C**opy to **t**ransmit **b**uffer). Please observe that data provided is transmitted directly by toggling the bit.

The data is then sent in the order received from the buffer to the connected Leuze device via the serial interface with the command: "SFB" (**S**end data from transmit **b**uffer). Please don't forget the suitable data frame!

Afterward, the buffer is again empty and can be written with new data.



Notice!

With this function, it is possible to temporarily store longer data strings in the gateway independent of how many bytes the used fieldbus can transmit at once. With this function, longer PT sequences or RFID write sequences, for example, can be transmitted, since the connected devices can, in this way, receive their commands (e.g., PT or W) in a continuous string. The respective frame (STX CR LF) is needed to differentiate between the individual telegrams.

Used status and control bits:

- CTB
- SFB
- W-ACK

If PLC data is provided and transferred without a state change of the CTB bit, it goes directly to the RS 232 interface with the set telegram data length. Incomplete (incl. data frame) or faulty telegrams can cause error messages in the connected device!

Examples for the activation of a Leuze device

In the data part (starting at byte 2) of the telegram to the gateway, a "+" (ASCII) is sent for activation.

This means that the hex value "2B" (corresponds to a "+") is to be entered in control or output byte 2. To deactivate the reading gate, a "2D" (hex) must be used instead (corresponds to a "-" ASCII).

7	6	5	4	3	2	1	0	
ND	Address 4	Address 3	Address 2	Address 1	Address 0	Broadcast	Command mode	Control byte 0
				CTB	SFB		R-ACK	Control byte 1
Data byte 1								
Data byte 2								Data
...								

7	6	5	4	3	2	1	0	
0	0	0	0	0	0	0	0	Output byte 0
0	0	0	0	0	0	0	0	Output byte 1
0	0	0	0	0	0	B	2	Output byte 2
0	0	0	0	0	0	0	0	Output byte 3

7	6	5	4	3	2	1	0	
0	0	0	0	0	0	0	0	Output byte 0
0	0	0	0	0	0	0	0	Output byte 1
0	0	0	0	0	0	B	2	Output byte 2
0	0	0	0	0	0	0	0	Output byte 3

Collective mode sequence diagram

Send long online commands to the DEV, read RS 232 answer from DEV

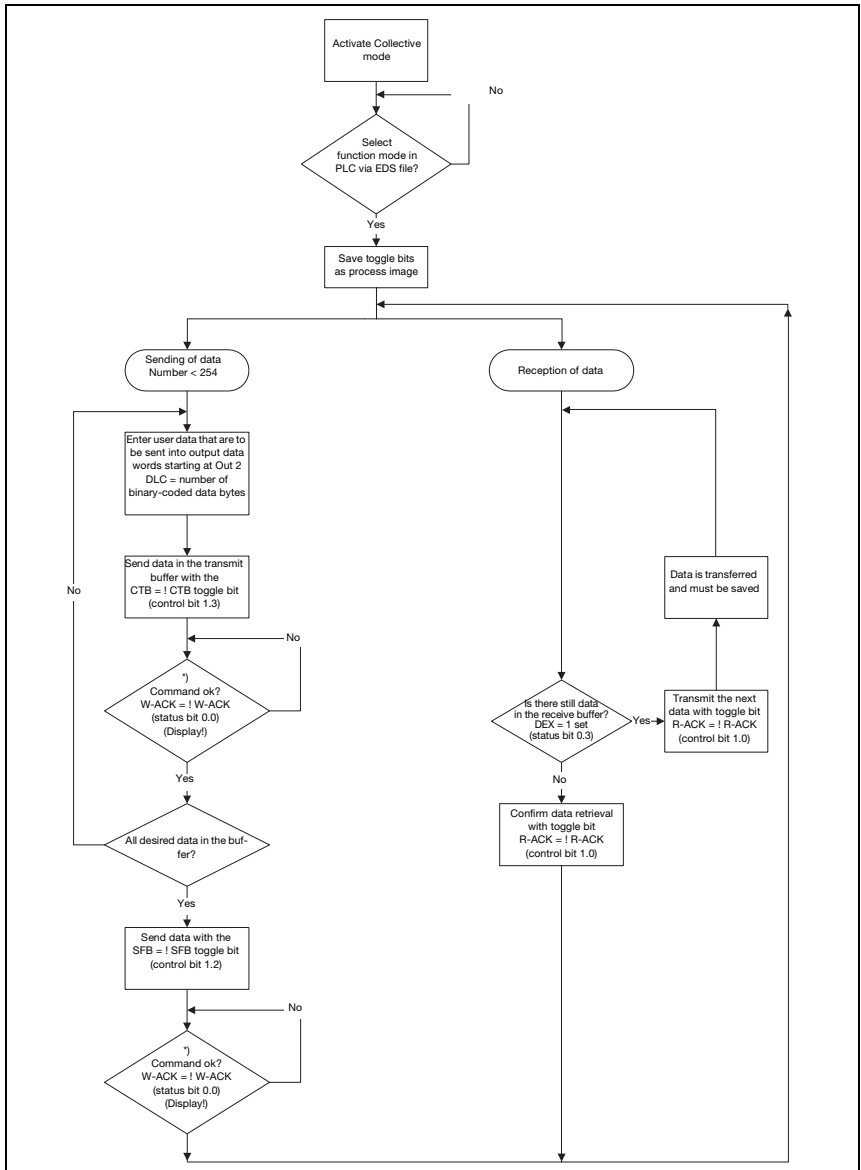

Figure 11.1: Data transmission scheme with long online commands

11.1.3 Command mode

One specific feature is the so-called Command mode, which is defined via the output control byte 0 (bit 0) ... and enables the control of the connected device per bit.

If the Command mode is activated (Command mode = "1"), no data is sent by the PLC to the Leuze end device via the gateway. The data from the MA to the PLC is transmitted in the selected operating mode (Transparent/Collective).

With the Command mode, it is possible to set various device-specific bits in the data- or parameter field that execute the corresponding serial commands (e.g., v, +, -, etc.). If, for example, the version of the Leuze end device is to be queried, the corresponding bit is to be set so that a "v" is sent to the Leuze device with the <STX> v <CR> <LF> frame.

The Leuze end device also answers the gateway with data (e.g. bar code content, NoRead, device version, etc.) in response to most commands. The answer is immediately passed on to the PLC by the gateway.



Notice!

The parameters available for the individual Leuze devices are listed in chapter 16. Command mode cannot be used with hand-held scanners.

Examples for the activation of a Leuze device

In Command mode, control or output byte 0.0 is to be set for activating the Command mode. Only the corresponding bit (control or output byte 2.1) then needs to be set for activating and deactivating the reading gate.

7	6	5	4	3	2	1	0	
0	0	0	0	0	0	0	1	Output byte 0
0	0	0	0	0	0	0	0	Output byte 1
0	0	0	0	0	0	1	0	Output byte 2
0	0	0	0	0	0	0	0	Output byte 3

Command mode sequence diagram

Set control byte 0, bit 0.0 to 1

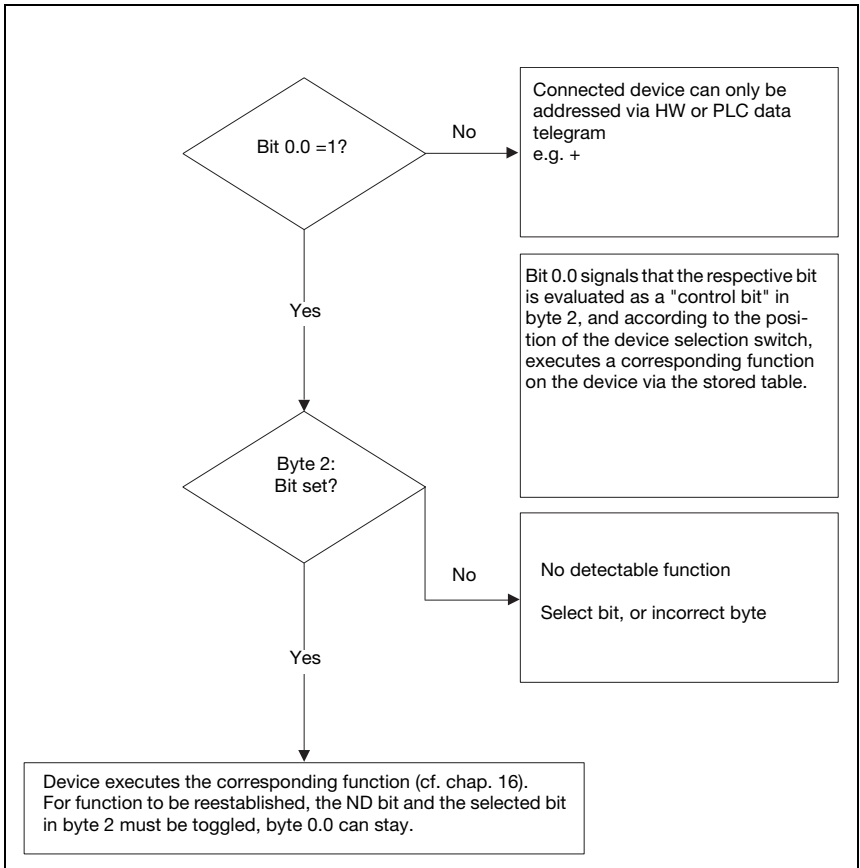

Figure 11.2: Execution of command after activation of the Command mode



Notice!

Further information on fieldbus telegram structure can be found in chapter 10.1. A specification of all usable commands can be found in chapter "Specifications for Leuze end devices" on page 80.

12 Commissioning and configuration

12.1 Measures to be performed prior to the initial commissioning

- ↳ Before commissioning, familiarize yourself with the operation and configuration of the MA 235*i*.
- ↳ **Before connecting the supply voltage**, recheck all connections and ensure that they have been properly made.

The Leuze device must be connected to the internal RS 232 device interface.

Connecting the Leuze device

- ↳ Open the housing of the MA 235*i* and lead the corresponding device cable (see chapter 14.7) through the middle threaded opening.
- ↳ Connect the cable to the internal device interface (X30, X31 or X32, see chapter 7.5.1).
- ↳ Use rotary switch S4 (see chapter 8.2.5) to select the connected device.
- ↳ Now screw the PG cable gland into the threaded opening to provide strain relief and ensure protection class IP 65.

Set CANopen device address

By setting the CANopen address, the MA 235*i* is assigned its respective station number. Each network device is thereby automatically informed that it is a slave on the CANopen with its specific address and that it is initialized and queried by the PLC.

The CANopen permits an address range from 0 to 127, the MA a range from 0 to 99. Other addresses must not be used for data communication.

- ↳ Set the station address of the gateway using the two rotary switches **S1** and **S2** (ones and tens places).

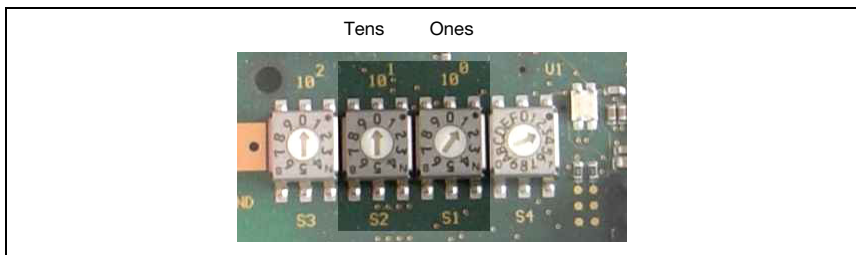

Figure 12.1: Rotary switch for setting the address

Set CANopen baud rate on the MA

The CANopen baud rate is defined for the entire network in the planning tool/control. The baud rate is set on the MA 235*i* via the baud rate selector switch. Only if the baud rates are the same is communication with the MA 235*i* possible.

↳ Set the baud rate of the gateway via the **S3** rotary switch to the value defined in the control.

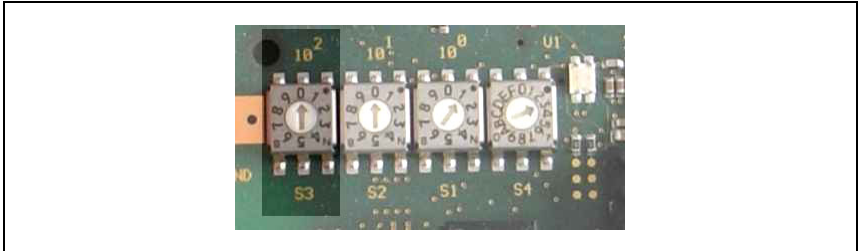

Figure 12.2: Rotary switch for setting baud rate

Switch position	Baud rate [kBd]
0	auto
1	10
2	20
3	50
4	100
5	125
6	250
7	500
8	800
9	1000

↳ Finally, close the housing of the MA 235*i*.



Attention!

Only then may the supply voltage be applied.

Upon startup of the MA 235*i*, the device selection switch is queried and the gateway automatically sets itself to the Leuze device.

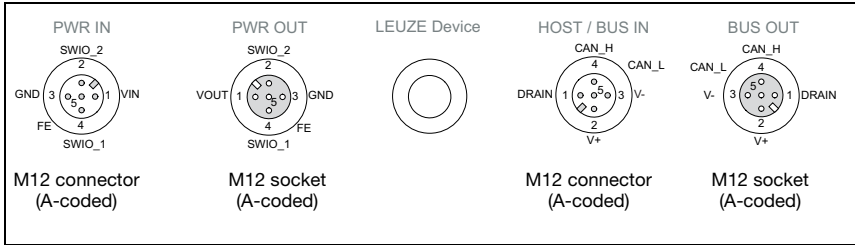

Figure 12.3: Connections of the MA 235i seen from below, device on mounting plate

☞ Check the applied voltage. It must be in the range between +18V ... 30VDC.

Connecting functional earth FE

☞ Ensure that the functional earth (FE) is connected correctly.

Unimpaired operation is only guaranteed when the functional earth is connected properly. All electrical disturbances (EMC couplings) are discharged via the functional earth connection.

On delivery, the SWIO 1/2 are connected in parallel on PWR IN/OUT. This connection can be separated with a jumper.

12.1.1 Connecting the power supply and the bus cable

- ☞ Ideally, use the ready-made cables listed in chapter 14.5.3 to connect the gateway to the power supply via the **PWR IN** connection.
- ☞ The ready-made cables listed in chapter 14.6.4 are preferred for connecting the gateway to the fieldbus via the **HOST / BUS IN** connection.
- ☞ If applicable, use the **BUS OUT** connection if you would like to construct a network with linear topology.

12.2 Starting the device

- ☞ Apply the supply voltage +18 ... 30VDC (typ. +24VDC); the MA 235i starts up. The PWR LED displays that it is ready for operation.

12.3 MA 235*i* in the CANopen system

🔗 Install the EDS file corresponding to the MA 235*i* in your planning tool/the control.



Notice!

You can find the EDS file at: www.leuze.com

The MA 235*i* is configured in the planning tool/control by means of the EDS file. The MA 235*i* is assigned an address in the planning tool, which then has to be set in the MA 235*i* via the S1 and S2 address switches. Only if the addresses are the same between the MA 235*i* and the control can communication be established.

After all parameters have been set in the planning tool/control, the download to the MA 235*i* takes place. The set parameters are now stored on the MA 235*i*.

Afterwards, all MA 235*i* parameters should be stored via upload in the control. This aids in retaining the parameters during device exchanges, as they are now also stored centrally in the control.

The CANopen baud rate is defined for the entire network in the planning tool/control. The baud rate is set on the MA 235*i* via the S3 baud rate selector switch.

Only if the baud rates are the same is communication with the MA 235*i* possible.

In a CANopen network, all participants have in principle equal privileges. Each participant can initiate its data transmission independently. Here, the arbitration specified by the CIA controls the access of the individual participants to the network. Generally, each CAN participant listens in on the bus. The transmission process is started only if the bus is not occupied by another CAN participant. When transmitting, the current bus status is always compared to the own transmitted frame.

If several participants start a transmission simultaneously, the arbitration process decides which participant gains access to the network next. The individual participants are integrated into a prioritization scheme via their bus address and the type of data to be transmitted (index address of the data). Process data (PDOs) of a device are transmitted with a higher priority than, for example, variable objects (SDOs) of a device.

The node address of the participant is another criterion for prioritizing a participant in the network. The smaller the node address, the higher the priority of the participant in the network.

Since every participant compares its own priority with that of the other participants at the time of bus access, the participants with low priority discontinue their transmission activities immediately. The participant with the highest priority obtains temporary access to the bus. The arbitration process controls the access of all participants so that even participants with a low priority have access to the bus.

12.4 Starting the MA 235*i* in the CANopen system

During starting up, the gateway runs through different states which are explained in brief in the following.

INIT

The MA 235*i* initializes itself. No direct communication between the master and MA 235*i* is possible. The CANopen master will transfer the MA 235*i* step by step into the "operational" state.

In the status change from "INIT" to "PREOP", the TwinCAT or master writes the so-called CANopen address (=station address) to the respective register of the CANopen slave controller (here: MA 235*i*). This CANopen address is typically specified in relation to the position, i.e., the master's address is 1000, the first slave's address is 1001, etc. This is also called the auto-increment method.

PRE-OPERATIONAL

The master and the MA 235*i* exchange application-specific initializations and device-specific parameters. In the PRE-OPERATIONAL state, configuration is initially possible via SDOs only.

SAFE-OPERATIONAL

The "Start Input Update" command puts the gateway into the "Safe-Operational" state. The master produces output data, but input data are not considered. This means the MA 235*i* does not return output data (=PLC input data) in SAFEOP. The gateway does not process input process data (=PLC output data). Mailbox communication via CoE services is possible.

OPERATIONAL

The "Start Output Update" command puts the gateway into the OPERATIONAL state. In this state, the MA 235*i* supplies valid input data and the master valid output data. After the MA 235*i* has detected the data received via the process data service, the state transition is confirmed by the MA 235*i*. If the activation of the output data was not possible, the gateway remains in the SAFE OPERATIONAL state and outputs an error message.

12.4.1 Device profile

CANopen describes the characteristics of participants in so-called profiles. However, a device profile for gateways is not defined.

The MA 235*i* is designed as a slave participant and cannot take on master functionality.

12.4.2 Object directories

All process data and parameters are stored as objects in the MA 235*i*. The object directory of the MA 235*i* is the compilation of all process data and parameters of the gateway.

An object directory is structured such that some objects within a device profile are mandatory while others are freely definable and stored in the manufacturer-specific object area.

The objects are uniquely identified using an index addressing scheme. The structure of the object directory, the assignment of the index numbers, as well as some mandatory entries are specified in the CIA standard DS301 for CANopen.

EDS file

For the user, the object directory of the MA 235*i* is stored as an EDS file (Electronic Data Sheet).

The EDS file contains all objects with index, sub-index, name, data type, default value, minimum and maximum, and access privileges. That means the EDS file describes the entire functionality of the MA 235*i*, and it is possible to adjust both the communication of the gateway with the control and the RS 232 interface.



Notice!

*The size of the input and output data is permanently set for CANopen: the MA 235*i* always provides the process data for transmission in this form: 8 bytes Tx and 8 bytes Rx.*

The EDS file has the name MA 235*i*.eds and is available for download on the Leuze home page.

Vendor ID for the MA 235*i*

The Vendor ID assigned by Leuze electronic for the MA 235*i* is $121_{\text{h}} = 289_{\text{d}}$.

Detailed information on the device description file and the object directory can be found in chapter 12.4.6.

12.4.3 SDOs and PDOs

The data exchange in CANopen distinguishes between service data objects (SDOs), which are used for transmitting the service data (parameters) from and to the object directory, and process data objects (PDOs), which are used to exchange the current process states.

12.4.4 SDOs

By using SDOs, all entries of the object directory can be accessed. Within one SDO call, only one object can be accessed at any one time. For this reason, a service data telegram must have a protocol structure which describes the exact target address by means of index and sub-index addressing. SDO telegrams place a part of the SDO addressing into the user data area. Eventually, a user data area with a width of 4 bytes out of the possible 8 bytes of user data remains for each SDO telegram.

The target address always responds to SDO transfers.

In the following, the index and sub-index address of the MA 235*i* parameters and variables can be found in the individual object descriptions.

12.4.5 PDOs

PDOs are objects (data, variables and parameters) from the object directory compiled (mapped) by the device manufacturer. A maximum of 8 bytes of user data from various objects can be mapped into one PDO.

A PDO can be received and evaluated by each participant (node). The model is referred to as the producer-consumer procedure.

Since there is no protocol structure in the telegram of a PDO, the participants in the network for whom these data are intended must know how the user data in the data area of the PDO are structured (which data are stored where in the user data area).

The exchange of process data is supported by the MA 235*i* via the following accesses:

- Event-controlled data transfer
Here, the data of a node are transmitted as a message whenever a change to the present state occurs.
- Polling with remote frames
The CAN node which has been defined as master in the network requests the desired information via query (via remote frame). The participant which has this information (or the required data) responds by sending the requested data.
- Synchronized mode
CANopen permits simultaneous querying of inputs and states of different participants and the simultaneous change of outputs or states. For this purpose, one uses the synchronization telegram (SYNC) transmitted by a master.
The SYNC telegram is a broadcast to all network devices with high priority and without data content. Generally, the master sends the SYNC telegram cyclically.
Participants working in synchronized mode read their data when receiving the SYNC message and then transmit them immediately afterwards as soon as the bus permits this (see explanation regarding arbitration process).
As the SYNC process can very quickly lead to high bus loads, another distinction is made between "event-controlled synchronization" and a "timer synchronization".
- Time-controlled transmission
In this case, the transmission of a PDO is triggered when an adjustable time period has elapsed. The time-controlled transmissions are set individually for each PDO via the so-called "inhibit time" or an "event timer". The respective parameters can be found in the objects 1800_n to 1803_n for the corresponding PDOs.
- Node monitoring
Heartbeat and guarding mechanisms are available for failure monitoring of the MA 235*i*. This is particularly important for CANopen, as the MA 235*i* may not respond regularly in the event-controlled operating mode. In case of guarding, the participants are cyclically queried for their state via data request telegrams (remote frame). In case of heartbeat, the nodes transmit their state themselves.
Heartbeat and guarding / life time are standard communication objects from the DS301 CANopen specification. The corresponding objects here are:
 - Heartbeat 1017_n
 - Guarding / Life time factor 100C_n and 100D_n

12.4.6 Object index

The object directory of the MA 235*i* is the compilation of all process data and parameters of the MA.

The following overview table shows all objects supported by the MA 235*i*.

Object address in hex	CANopen-specific object area
1000	Device Type
1008	Manufacturer Device Name (contains the device name of the manufacturer)
1018	Identity Object (contains general information regarding the device)
2000	Inputs (Input Data, 8 bytes by 8 bytes (Rx))
2200	Outputs (Output Data, 8 bytes by 8 bytes (Tx))
3000	Serial line mode
3001	Serial Settings (RS 232)

Afterwards, you will find the respective detailed descriptions of the individual objects.

12.4.6.1 Object 1000_n, Device Type

The object describes the MA 235*i* device type.

Index (hex)	Sub-index (hex)	Name	Data type	Access	Value range			Remark
					Minimum	Maximum	Default	
1000	--	Device type	u32	ro	--	--	0000	

12.4.6.2 Object 1008_h Manufacturer Device Name

This object contains the name of the gateway.

Index (hex)	Sub-index (hex)	Name	Data type	Access	Value range			Remark
					Minimum	Maximum	Default	
1008	--	Manufacturer Device Name	u32	ro	--	--	MA235i V1.x.x.x	Device names of the manufacturer

12.4.6.3 Object 1018_h Manufacturer Device Name

This object contains general specifications about the MA 235*i*.

Index (hex)	Sub-index (hex)	Name	Data type	Access	Value range			Remark
					Minimum	Maximum	Default	
1018	01	Vendor ID	u32	ro	--	--	121 _h	Manufacturer ID number
	02	Product Code	u32	ro	--	--	F1 _h	
	03	Revision	u32	ro	--	--	--	
	04	Serial Number	u32	ro	--	--	--	

The Vendor ID assigned by Leuze electronic for the MA 235*i* is 121_h = 289_d.

12.4.6.4 Object 2000_h Inputs

The object describes the input data of the MA 235*i*, which is transmitted cyclically, 8 bytes by 8 bytes (Rx).

Index (hex)	Sub-index (hex)	Name	Data type	Access	Value range			Remark
					Minimum	Maximum	Default	
2000	--	8 Byte Input	u32	rw		--	x00	

12.4.6.5 Object 2200_h Outputs

The object describes the output data of the MA 235*i*, which is transmitted cyclically, 8 bytes by 8 bytes (Tx).

Index (hex)	Sub-index (hex)	Name	Data type	Access	Value range			Remark
					Minimum	Maximum	Default	
2200	--	8 Byte Output	u32	rw	--	--	x00	

12.4.6.6 Object 3000_n, Serial Line Mode

The object describes the function mode of the MA 235*i*.

Index (hex)	Sub-index (hex)	Name	Data type	Access	Value range			Remark
					Minimum	Maximum	Default	
3000	--	Data Mode	u32	rw	--	--	Transparent Mode (0)	

Parameter value:

- 0 = Transparent Mode
- 1 = Collective Mode

12.4.6.7 Object 3001_n, Serial Settings

The object describes the serial RS 232 settings of the MA 235*i*.

Index (hex)	Sub-index (hex)	Name	Data type	Access	Value range			Remark
					Minimum	Maximum	Default	
3001	--	Serial Settings	u32	rw	--	--		
	01	Use Rotary Switch	u32	rw	--	--	Use Rotary Switch (1)	
	02	Baud Rate	u32	rw	--	--	9600 Baud (96)	
	03	Data Bits	u32	rw	--	--	8 Data Bits (8)	
	04	Parity	u32	rw	--	--	None (1)	
	05	Stop Bits	u32	rw	--	--	1 Stop Bit (1)	

Use Rotary Switch

Parameter value:

- 0 = use rotary switch (default)
- 1 = use EDS settings

RS 232 Baud Rate

Parameter value:

- 3 = 300
- 6 = 600
- 12 = 1200
- 24 = 2400
- 48 = 4800
- 96 = 9600 (default)
- 192 = 19200
- 384 = 38400
- 576 = 57600
- 1152 = 115200

RS 232 Data Bits

Parameter value:

7 = 7 bits

8 = 8 bits (default)

RS 232 Parity

Parameter value:

1 = none (default)

2 = even

3 = odd

RS 232 Stop Bits

Parameter value:

1 = 1 bit (default)

2 = 2 bits

12.5 Setting the read parameters on the Leuze device

Commissioning the Leuze device

To commission a read station, you must prepare the Leuze device on the MA 235*i* for its reading task. Communication with the Leuze device occurs via the service interface.



Notice!

For further information on connecting and using the service interface, see chapter 9 "Configuration".

↳ *To do this, connect the Leuze device to the MA 235*i*.*

Depending on the Leuze device, this occurs either via a connection cable (accessory no.: KB 031-1000) or directly on the MA 235*i*. The service connector and corresponding switches can be accessed with the housing cover open.

↳ *Select the "DEV" service switch position.*

Connect the service interface; call up the terminal program

↳ *Connect your PC to the service connector via the RS 232 cable.*

↳ *On the PC, call up a terminal program (e.g., BCL-Config) and check whether the interface (COM 1 or COM 2) to which you have connected the MA 235*i* is set to the following Leuze standard setting: 9600 baud, 8 data bits, no parity, 1 stop bit and STX, data, CR, LF.*

You can download the config. tool from www.leuze.com for BCL, RFID, etc.

In order to communicate with the connected Leuze device, the **STX, data, CR, LF** framing must be set on the PC terminal program, as the Leuze device is preconfigured ex works for this frame character.

STX (02h):	Prefix 1
CR (0Dh):	Postfix 1
LF (0Ah):	Postfix 2

Operation

↳ Switch the MA 235*i* to switch position "RUN" (operation).

The Leuze device is now connected to the fieldbus. Activation of the Leuze device can now occur via the switching input on the MA 235*i*, via the process data word Out bit 1 (bit 0.2) or by transmitting a "+" command to the Leuze device (see chapter 16 "Specifications for Leuze end devices"). For further information on the fieldbus transmission protocol, see see chapter 10 "Telegram".

Reading out information in service mode

↳ Set the service switch of the gateway to switch position "MA" (gateway).

↳ Send a "v" command to call up all service information of the MA 235*i*.

An overview of the available commands and information can be found in chapter "Reading out information in Service mode" on page 41.

12.5.1 Specific feature for the use of hand-held scanners (bar code and 2D devices, combi devices with RFID)



Notice!

A description of the device configuration and the required codes can be found in the respective documentation at www.leuze.com.

12.5.1.1 Cable-connected hand-held scanners on the MA 235*i*

All hand-held scanners and mobile combi devices available in the Leuze electronic product line can be used with the corresponding connection cable.

When using the MA 235*i*, the voltage supply of the hand-held scanner (4.75 ... 5.25VDC/ at 1 A) can be connected to the interface by means of a cable via the 9-pin Sub-D connector (voltage on PIN 9). The corresponding cable is to be selected for the respective hand-held scanner and ordered separately. The 9-pin Sub-D cable (KB JST-HS-300, part no. 50113397) is connected to this cable, which is connected to the MA 235*i*. This cable must also be ordered separately.

In this example, triggering occurs by means of a trigger button on the hand-held scanner.



Notice!

When using third-party devices, check the pin assignment and interface settings without fail and adjust them if necessary.

12.5.1.2 Wireless hand-held scanners on the MA 235i

All wireless hand-held scanners and mobile combi devices available in the Leuze electronic product line can be used with the corresponding connection cable via the base station.

A 230VAC connection (socket) is usually necessary for the charging station. Here, a data connection of the charging station is established with the MA 235i. The corresponding cable is to be selected for the respective hand-held scanner and ordered separately. The 9-pin Sub-D cable (KB JST-HS-300, part no. 50113397) is connected to this cable, which is connected to the MA 235i. This cable must also be ordered separately.

In this example, triggering occurs by means of a trigger button on the hand-held scanner. The following codes for configuring the devices are necessary for these devices as well.

12.5.2 Specific features in the operation of an RFM/RFI

When using the MA 235i in connection with an RFID device, we recommend a data width of at least 24 bytes to be able to transmit information to or from the reader in a telegram.

Shown here is a sample telegram for a write command in combination with an RFID device.



Notice!

Also note that all characters which are sent to a transponder are hex-encoded ASCII characters. Each of these (hexadecimal) characters is, in turn, to be handled as an individual ASCII character and converted to hexadecimal format for transmission via the fieldbus.

Example:

7	6	5	4	3	2	1	0	
00	00	00	00	00	00	00	00	Control byte 0
00	00	00	00	00	00	00	00	Control byte 1
34	35	31	31	30	35	30	57	Data
00	00	34	37	33	37	35	36	

HEX	57	30	35	30	31	31	35	34	36	35	37	33	37	34
CHAR	W	0	5	0	1	1	5	4	6	5	7	3	7	4
Plain text	T e s t													

13 Diagnostics and troubleshooting

If problems should occur during commissioning of the MA 235*i* you can refer to the following table. Typical errors and their possible causes are described here as well as tips for their elimination.

13.1 General causes of errors

Error	Possible error causes	Measures
No data to the PLC	Device setting incorrect.	Adjust device settings (data protocol, baud rate, etc.).
No data sporadically and/or the device "stalls"	Problems with the voltage supply.	Check voltage range, supply separately if needed.
Data loss (DL bit)	Data telegram longer than the bus telegram in bus cycle/memory size.	Increase in bus telegram length. Toggle out data earlier.
Data in the RS 232 instead of in the buffer	Incorrect order	Correct order: Provide data, toggle CTB.
PWR status LED on the circuit board		
Off	No supply voltage connected to the device.	Check supply voltage.
	Hardware error.	Send the device to customer service.
Green/orange, flashing	Device in boot mode.	No valid firmware, send device to customer service.
Continuous orange light	Device error.	Send the device to customer service.
	Firmware update failed.	
PWR LED on the housing (see figure 5.1 on page 22)		
Off	No supply voltage connected to the device.	Check supply voltage.
Green, flashing	SERVICE active.	Service switch on RUN.
Red, flashing	Incorrect baud rate / address.	Check switch settings. Check baud rate or address.
Red continuous light	Device error.	Send the device to customer service.
CAN LED on the housing (see figure 5.1 on page 22)		
Off	No connection	Check wiring/IP address.

Table 13.1: General causes of errors

13.2 Interface errors

Error	Possible error causes	Measures
No communication via CANopen interface CAN continuous red light LED	Incorrect wiring.	Check wiring.
	Incorrect baud rate / address different baud rate setting in control and MA: no communication. Address >99: no communication.	Check switch settings: Baud rate selector switch S3. Address switch S1, S2.
Sporadic errors at the CANopen interface	Incorrect wiring.	Check wiring. In particular, check wire shielding. Check the cable used.
	Effects due to EMC.	Check shielding (shield covering in place up to the clamping point). Check grounding concept and connection to functional earth (FE). Avoid EMC coupling caused by power cables laid parallel to device lines.
	Overall network expansion exceeded.	Check max. network expansion as a function of the max. cable lengths.

Figure 13.1: Interface error



Notice!

Please use **chapter 13 as a master copy** should servicing be required.

Cross the items in the "Measures" column which you have already examined, fill out the following address field and fax the pages together with your service contract to the fax number listed below.

Customer data (please complete)

Device type:	
Company:	
Contact partner / department:	
Phone (direct):	
Fax:	
Street / No:	
ZIP code/City:	
Country:	

Leuze Service fax number:

+49 7021 573 - 199

14 Type overview and accessories

14.1 Part number code

MA 2xx i

	i =	Integrated fieldbus technology
Interface	04	PROFIBUS DP
	08	Ethernet TCP/IP
	35	CANopen
	38	EtherCAT
	48	PROFINET RT
	55	DeviceNet
	58	EtherNet/IP
	MA	Modular interfacing unit

14.2 Type overview

Type designation	Description	Description
MA 204 <i>i</i>	PROFIBUS gateway	50112893
MA 208 <i>i</i>	Ethernet TCP/IP gateway	50112892
MA 235 <i>i</i>	CANopen gateway	50114154
MA 238 <i>i</i>	EtherCAT gateway	50114155
MA 248 <i>i</i>	PROFINET-IO RT gateway	50112891
MA 255 <i>i</i>	DeviceNet gateway	50114156
MA 258 <i>i</i>	EtherNet/IP gateway	50114157

Table 14.1: Type overview MA 2xx*i*

14.3 Accessory terminating resistor

Type designation	Description	Part no.
TS 01-4-SA	120 ohm M12 terminating resistor for CANopen	50040099

Table 14.2: Accessory terminating resistor

14.4 Accessory connectors

Type designation	Description	Description
KD 095-5A	M12 socket for voltage supply	50020501
KS 095-4A	M12 connector for SW IN/OUT	50040155

Table 14.3: Connectors for the MA 235*i*

14.5 Accessory ready-made cables for voltage supply

14.5.1 Contact assignment of PWR connection cable

PWR IN (5-pin socket, A-coded)			
<p>PWR IN SWIO_2 VIN 1 2 3 GND 4 FE SWIO_1 M12 socket (A-coded)</p>	Pin	Name	Core color
	1	VIN	brown
	2	SWIO_2	white
	3	GND	blue
	4	SWIO_1	black
	5	FE	gray
	Thread	FE	bare

PWR OUT (5-pin connector, A-coded)			
<p>PWR OUT SWIO_2 GND 3 2 1 VOUT 4 FE SWIO_1 M12 connector (A-coded)</p>	Pin	Name	Core color
	1	VOUT	brown
	2	SWIO_2	white
	3	GND	blue
	4	SWIO_1	black
	5	FE	gray
	Thread	FE	bare

14.5.2 Specifications of the cables for voltage supply

Operating temperature range	in rest state:	-30°C ... +70°C
	in motion:	5°C ... +70°C
Material	sheathing:	PVC
Bending radius	> 50mm	

14.5.3 Order codes of the cables for voltage supply

Type designation	Description	Part no.
K-D M12A-5P-5m-PVC	M12 socket for PWR, axial plug outlet, open cable end, cable length 5m	50104557
K-D M12A-5P-10m-PVC	M12 socket for PWR, axial plug outlet, open cable end, cable length 10m	50104559

Table 14.4: PWR cables for the MA 235*i*

14.6 Accessory ready-made cables for bus connection

14.6.1 General information

- Cable KB DN... for connecting to CANopen via M12 connector
- Standard cable available in lengths from 2 ... 30m
- Special cables on request

14.6.2 Contact assignment of M12-CANopen connection cable KB DN...

CANopen connection cable (5-pin socket/plug, A-coded)				
	Pin	Name	Core color	Remark
<p>BUS OUT</p> <p>CAN_H 4 CAN_L 3 DRAIN 1 5 2 V+</p> <p>M12 socket (A-coded)</p>	1	Drain	-	Shield
	2	V+	red	Supply voltage data V+
	3	V-	black	Supply voltage data V-
	4	CAN_H	white	Data signal CAN_H
	5	CAN_L	blue	Data signal CAN_L
<p>BUS IN</p> <p>CAN_H 4 CAN_L 3 V- 5 1 DRAIN 2 V+</p> <p>M12 connector (A-coded)</p>	Thread	FE	-	Functional earth (housing)

14.6.3 Specifications of M12-CANopen connection cable KB DN...

Operating temperature range	in rest state: -40°C ... +80°C in motion: -5°C ... +80°C
Material	the cables comply with the CANopen requirements, free of halogens, silicone and PVC
Bending radius	> 80mm, suitable for drag chains

14.6.4 Order codes of M12-CANopen connection cable KB DN...

Type designation	Remark	Part no.
KB DN/CAN-2000-BA	M12 socket for BUS IN, axial connector, open cable end, cable length 2m	50114692
KB DN/CAN-5000-BA	M12 socket for BUS IN, axial connector, open cable end, cable length 5m	50114696
KB DN/CAN-10000-BA	M12 socket for BUS IN, axial connector, open cable end, cable length 10m	50114699
KB DN/CAN-30000-BA	M12 socket for BUS IN, axial connector, open cable end, cable length 30m	50114701
KB DN/CAN-2000-SA	M12 connector for BUS OUT, axial connector, open cable end, cable length 2m	50114693
KB DN/CAN-5000-SA	M12 connector for BUS OUT, axial connector, open cable end, cable length 5m	50114697
KB DN/CAN-10000-SA	M12 connector for BUS OUT, axial connector, open cable end, cable length 10m	50114700
KB DN/CAN-30000-SA	M12 connector for BUS OUT, axial connector, open cable end, cable length 30m	50114702
KB DN/CAN-1000-SBA	M12 plug + M12 socket for CANopen, axial connectors, cable length 1m	50114691
KB DN/CAN-2000-SBA	M12 plug + M12 socket for CANopen, axial connectors, cable length 2m	50114694
KB DN/CAN-5000-SBA	M12 plug + M12 socket for CANopen, axial connectors, cable length 5m	50114698

Table 14.5: Bus connection cable for the MA 235*i*

14.7 Accessory ready-made cables for connecting Leuze Ident devices

14.7.1 Order codes for the device connection cables

Type designation	Description	Part no.
KB JST-3000	MA 31, BCL 90, IMRFU-1 (RFU), cable length 3m	50115044
KB JST-HS-300	Hand-held scanner, cable length 0.3m	50113397
KB JST-M12A-5P-3000	BPS 8, BCL 8, cable length 3m	50113467
KB JST-M12A-8P-Y-3000	LSIS 4x2i, cable length 3m	50113468
KB JST-M12A-8P-3000	LSIS 122, LSIS 222, cable length 3m	50111225
K-D M12A-5P-5m-PVC	Voltage supply, cable length 5m	50104557
K-D M12A-5P-10m-PVC	Voltage supply, cable length 10m	50104559
K-DS M12A-MA-5P-3m-S-PUR	ODS 96B with RS 232	50115049
K-DS M12A-MA-8P-3m-S-PUR	ODSL 30/D 232-M12	50115050
K-DS M12A-MA-5P-3m-1S-PUR	Konturflex Quattro RSX	50116791
KB 500-3000-Y	BCL 500i, cable length 3m	50110240
KB 301-3000-MA200	BCL 300i, cable length 3m	50120463

Table 14.6: Device connection cables for the MA 235*i*



Notice!

The BCL 22 devices with JST connector, RFM xx and RFI xx can be connected directly with the injection molded device cable.

14.7.2 Contact assignment for the device connection cables

K-D M12A-5P-5000/10000 connection cable (5-pin with molded connector), open cable end		
	Pin	Core color
	1	brown
	2	white
	3	blue
	4	black
	5	gray

KB JST 3000 (RS 232 connection cable, JST pin strip 10-pin, open cable end)		
Signal	Core color	JST 10-pin
TxD 232	red	5
RxD 232	brown	4
GND	orange	9
FE	shield	10

15 Maintenance

15.1 General maintenance information

The MA 235*i* does not require any maintenance by the operator.

15.2 Repairs, servicing

Repairs to the device must only be carried out by the manufacturer.

↳ *Contact your Leuze distributor or service organization should repairs be required. The addresses can be found on the inside of the cover and on the back.*



Notice!

When sending devices to Leuze electronic for repair, please provide an accurate description of the error.

15.3 Disassembling, packing, disposing

Repacking

For later reuse, the device is to be packed so that it is protected.



Notice!

Electrical scrap is a special waste product! Observe the locally applicable regulations regarding disposal of the product.

16 Specifications for Leuze end devices

Serial interface and Command mode

The corresponding Leuze end device can be selected while configuring the fieldbus gateway (see chapter 9 "Configuration").

The exact specifications for the individual Leuze end devices can be found in the following sections and in the device description.

The corresponding serial command is sent to the Leuze end device in Command mode. To send the corresponding command to the RS 232 device after activating the Command mode in byte 0 (control bit 0.0), set the corresponding bit in byte 2.

The Leuze end device also responds to most commands by sending data, such as the bar code contents, NoRead, device version, etc., back to the gateway. The answer is not evaluated by the gateway, but is instead passed on to the PLC.

For the BPS 8, BPS 300i and hand-held scanners, a number of specific features are to be noted.



Notice!

Please note that Leuze only assumes liability for the function of Leuze products. When using third-party devices, Leuze does not assume liability for the function of third-party devices!

16.1 Standard setting, KONTURflex (S4 switch position 0)

This switch position can be used with almost all devices, since a data frame is transmitted along with it if necessary. A 00h in the data range of the control is interpreted as the end of a telegram/invalid, however.

The distance between two successive telegrams (without frame) must be more than 20ms in this switch position, since there is otherwise no clear separation between them. If necessary, the settings have to be adjusted on the device.

Leuze measuring sensors with RS 232 interface (such as a KONTURflex Quattro RS) do not necessarily use a telegram frame, which is why these are also operated in switch position 0.

Specifications for the serial interface

Default parameter	Standard
Baud rate	9600
Data mode	8N1
Handshake	no
Protocol	framing protocol without acknowledgment
Frame	<Data>
Data Mode	transparent



Notice!

The data frame is specified via the switch position. Only the data mode and the baud rate can also be set via the EDS file.

The factory setting corresponds to S4 switch position 0.

KONTURflex specifications

Settings on the MA 235*i*

- CANopen address is freely selectable
- Device selection switch at position "0"

Settings on the CANopen

- Produced/Consumed data settings:
Dependent on number of beams used, but at least "8 bytes In"
- User Parameters:
"Transparent Mode", "Use EDS Settings", Baudrate 38400, "8 Data Bits", "No parity",
"2 Stop Bits"

KONTURflex settings

First, the following settings are to be performed on the device using KONTURFlex-Soft:

- Either "Autosend (fast)" or "Autosend with data in Modbus format"
- Repeat time "31.5ms"
- Autosend baud rate "38.4KB"
- 2 stop bits, no parity

16.2 Bar code reader BCL 8 (S4 switch position 1)

Specifications for the serial interface

Default parameter	BCL 8
Baud rate	9600
Data mode	8N1
Handshake	no
Protocol	framing protocol without acknowledgment
Frame	<STX> <Data> <CR> <LF>

Specifications for Command mode

To activate the Command mode, bit 0 must be set to 1 in control byte 0.

For further information, see chapter 11.1.3 "Command mode", figure 11.2.

Control bit	Meaning	Corresponds to serial command (ASCII)
0	Version query	v
1	Activation / deactivation reading gate	+ / -
2	Reference-code 1 teach-in	RT1
3	Reference-code 2 teach-in	RT2
4	Automatic configuration of reading task activation / deactivation	CA+ / CA-
5	Switching output 1 activation	OA1
6		
7	Switching output 1 deactivation	OD1
8	System standby	SOS
9	System active	SON
10	Query reflector polling	AR?
11	Output version of the boot kernel with check sum	VB
12	Output version of the decoder program with check sum	VK
13	Reset parameters to default values	PC20
14	Device restart	H

Recommended settings

- Input data: 8 bytes
Use of the Collective mode for codes with a number of digits > 4.
- Output data: 8 bytes

16.3 Bar code reader BCL 22 (S4 switch position 2)

Specifications for the serial interface

Default parameter	BCL 22
Baud rate	9600
Data mode	8N1
Handshake	no
Protocol	framing protocol without acknowledgment
Frame	<STX> <Data> <CR> <LF>

Specifications for Command mode

To activate the Command mode, bit 0 must be set to 1 in control byte 0.

For further information, see chapter 11.1.3 "Command mode", figure 11.2.

Control bit	Meaning	Corresponds to serial command (ASCII)
0	Version query	v
1	Activation / deactivation reading gate	+ / -
2	Reference-code 1 teach-in	RT1
3	Reference-code 2 teach-in	RT2
4	Automatic configuration of reading task activation / deactivation	CA+ / CA-
5	Switching output 1 activation	OA1
6	Switching output 2 activation	OA2
7	Switching output 1 deactivation	OD1
8	Switching output 2 deactivation	OD2
9		
10		
11	Output version of the boot kernel with check sum	VB
12	Output version of the decoder program with check sum	VK
13	Reset parameters to default values	PC20
14	Device restart	H
15		

Recommended settings

- Input data: 8 bytes
Use of the Collective mode for codes with a number of digits > 4.
- Output data: 8 bytes

16.4 Bar code reader BCL 300i, BCL 500i, BCL 600i (S4 switch position 4)

Specifications for the serial interface

Default parameter	BCL 300i, BCL 500i, BCL 600i
Baud rate	9600
Data mode	8N1
Handshake	no
Protocol	framing protocol without acknowledgment
Frame	<STX> <Data> <CR> <LF>

Specifications for Command mode

To activate the Command mode, bit 0 must be set to 1 in control byte 0.

For further information, see chapter 11.1.3 "Command mode", figure 11.2.

Control bit	Meaning	Corresponds to serial command (ASCII)
0	Version query	v
1	Activation / deactivation reading gate	+ / -
2	Reference code teach-in activation / deactivation	RT+ / RT-
3		
4	Autom. configuration of reading task activation / deact.	CA+ / CA-
5	Switching output 1 activation	OA1
6	Switching output 2 activation	OA2
7	Switching output 1 deactivation	OD1
8	Switching output 2 deactivation	OD2
9		
10		
11		
12		
13	Parameter - difference to default parameter set	PD20
14	Reset parameters to default values	PC20
15	Device restart	H

Recommended settings

- Input data: 8 bytes
Use of the Collective mode for codes with a number of digits > 4.
- Output data: 8 bytes

16.5 Bar code reader BCL 90, BCL 900i (S4 switch position 5)

Specifications for the serial interface

Default parameter	BCL 90, BCL 900i
Baud rate	9600
Data mode	8N1
Handshake	no
Protocol	framing protocol without acknowledgment
Frame	<STX> <Data> <CR> <LF>

Specifications for Command mode

To activate the Command mode, bit 0 must be set to 1 in control byte 0.

For further information, see chapter 11.1.3 "Command mode", figure 11.2.

Control bit	Meaning	Corresponds to serial command (ASCII)
0	Version query	v
1	Activation / deactivation reading gate	+ / -
2	Configuration mode	11
3	Alignment mode	12
4	Read operation	13
5		
6		
7		
8		
9		
10		
11		
12		
13		
14	Reset parameters to default values	PC20
15	Device restart	H

Recommended settings

- Input data: 8 bytes
Use of the Collective mode for codes with a number of digits > 4.
- Output data: 8 bytes



Notice!

When using the command mode, make sure that 00H is shown in the data range; otherwise the device only performs one alignment cycle.

16.6 LSIS 122, LSIS 222 (S4 switch position 6)

Specifications for the serial interface

Default parameter	LSIS 122, LSIS 222
Baud rate	9600
Data mode	8N1
Handshake	no
Protocol	framing protocol without acknowledgment
Frame	<STX> <Data> <CR> <LF>

Specifications for Command mode

To activate the Command mode, bit 0 must be set to 1 in control byte 0.

For further information, see chapter 11.1.3 "Command mode", figure 11.2.

Control bit	Meaning	Corresponds to serial command (ASCII)
0	Version query	i
1	Activation/Deactivation of reading gate: 12h/14h (LSIS 122 only)	<DC2> / <DC4>
2	Activation of reading gate (LSIS 222 only)	<SYN>T<CR>
3	Deactivation of reading gate (LSIS 222 only)	<SYN>U<CR>
4		
5		
6		
7		
8		
9		
10		
11		
12		
13		
14		
15		

Recommended settings

- Input data: 8 bytes
Use of the Collective mode for codes with a number of digits > 4.
- Output data: 8 bytes

16.7 LSIS 4x2i, DCR 202i (S4 switch position 7)

Specifications for the serial interface

Default parameter	LSIS 4x2i, DCR 202i
Baud rate	9600
Data mode	8N1
Handshake	no
Protocol	framing protocol without acknowledgment
Frame	<STX> <Data> <CR> <LF>

Specifications for Command mode

To activate the Command mode, bit 0 must be set to 1 in control byte 0.

For further information, see chapter 11.1.3 "Command mode", figure 11.2.

Control bit	Meaning	Corresponds to serial command (ASCII)
0	Version query	v
1	Image acquisition trigger	+
2		
3		
4		
5		
6		
7		
8		
9		
10		
11		
12		
13		
14		
15		

Recommended settings

- Input data: 8 bytes
Use of the Collective mode for codes with a number of digits > 4.
- Output data: 8 bytes

16.8 Hand-held scanner (S4 switch position 8)

Specifications for the serial interface

Default parameter	Hand-held scanner
Baud rate	9600
Data mode	8N1
Handshake	no
Protocol	framing protocol without acknowledgment
Frame	<Data> <CR> <LF>



Notice!

Command mode cannot be used with hand-held scanners.

Recommended settings

- Input data: 8 bytes
Use of the Collective mode for codes with a number of digits > 4.
- Output data: none

16.9 RFI, RFM, RFU RFID readers (S4 switch position 9)

Specifications for the serial interface

Default parameter	RFM 12,RFM 32 and RFM 62 RFI 32 RFU (via IMRFU)
Baud rate	9600
Data mode	8N1
Handshake	no
Protocol	framing protocol without acknowledgment
Frame	<STX> <Data> <CR> <LF>

Specifications for Command mode

To activate the Command mode, bit 0 must be set to 1 in control byte 0.
For further information, see chapter 11.1.3 "Command mode", figure 11.2.

Control bit	Meaning	Corresponds to serial command (ASCII)
0	Version query	v ¹⁾
1	Activation / deactivation reading gate	+ / -
2		
3		
4		
5		
6		
7		
8		
9		
10		
11		
12		
13		
14	Reset parameters to default values	R ¹⁾
15	Device restart	H

1) Not for IMRFU/RFU

Recommended settings

- Input data: 8 bytes
Use of the Collective mode for codes with a number of digits > 4.
- Output data: 8 bytes

The RFID devices expect the telegrams / data in HEX format.

16.10 BPS 8 bar code positioning system (S4 switch position A)

Specifications for the serial interface

Default parameter	BPS 8
Baud rate	57600
Data mode	8N1
Handshake	no
Protocol	binary protocol without acknowledgment
Frame	<Data>

Specifications for Command mode

To activate the Command mode, bit 0 must be set to 1 in control byte 0.

For further information, see chapter 11.1.3 "Command mode", figure 11.2.

Control bit	Meaning	Corresponds to serial command (HEX)	
		byte 1	byte 2
0	Request diagnostic info	01	01
1	Request marker info	02	02
2	Request SLEEP mode	04	04
3	Request position info	08	08
4	Request individual measurement	10	10
5			
6			
7			
8			
9			
10			
11			
12			
13			
14			
15			

Recommended settings

- Input data: 8 bytes
- Output data: 8 bytes

In this switch position, the MA automatically sends a position request to the BPS 8 every 10ms until another command comes via the control. Automatic request only restarts when a new position request is sent by the PLC or when the MA is restarted.

16.11 BPS 300i bar code positioning system, ODSL xx optical distance sensors with RS 232 interface (S4 switch position B)



Notice!

In this switch position, 6-byte data (fixed) is always expected by the device. This is why a quick telegram sequence can be transmitted reliably even without a data frame.

BPS 300i

Specifications for the serial interface

Default parameter	BPS 300i
Baud rate	38400
Data mode	8N1
Handshake	no
Protocol	binary protocol without acknowledgment
Frame	<Data>

Specifications for Command mode

To activate the Command mode, bit 0 must be set to 1 in control byte 0.

For further information, see chapter 11.1.3 "Command mode", figure 11.2.

Control bit	Meaning	Corresponds to serial command (ASCII)
0	Transmit individual position value = single shot	COF131
1	Cyclically transmit position values	COF232
2	Stop cyclical transmission	COF333
3	Laser diode on	COF434
4	Laser diode off	COF535
5	Transmit single speed value	COF636
6	Cyclically transmit speed values	COF737
7	Transmit single position and speed value	COF838
8	Cyclically transmit position and speed values	COF939
9	Transmit marker information	COFA3A
10	Not used / reserved	
11	Transmit diagnostic information	COFC3C
12	Activate standby	COFD3D
13		
14		
15		

Recommended settings

- Input data: 8 bytes
Use of the Collective mode for codes with a number of digits > 4.
- Output data: 8 bytes

ODSL 9, ODSL 30 and ODSL 96B



Notice!

The default settings of the ODS serial interface have to be adjusted! Further information on configuration of the interface can be found in the technical description of the corresponding device.

Specifications for the serial interface

Default parameter	ODSL xx
Baud rate	38400
Data mode	8N1
Handshake	no
Protocol	ASCII transmission, 5-digit measurement value
Frame	<Data>

Specifications for Command mode

Command mode cannot be used with the ODSL 9, ODSL 30 and ODSL 96B.

The ODSL 9/96B is to be operated in the "Precision" measure mode. The mode is set through the display menu via `Application -> Measure mode -> Precision`. You can find more details on this in the technical description.

16.12 Modular interfacing unit MA 3x (S4 switch position C)

Specifications for the serial interface

Default parameter	MA 3x
Baud rate	9600
Data mode	8N1
Handshake	no
Protocol	framing protocol without acknowledgment
Frame	<STX> <Data> <CR> <LF>

Specifications for Command mode

To activate the Command mode, bit 0 must be set to 1 in control byte 0.

For further information, see chapter 11.1.3 "Command mode", figure 11.2.

Control bit	Meaning	Corresponds to serial command (ASCII)
0	Version query	v
1		
2		
3		
4		
5		
6		
7		
8		
9		
10		
11		
12		
13		
14	Reset parameters to default values	PC20
15	Device restart	H

Recommended settings

- Input data: 8 bytes
Use of the Collective mode for codes with a number of digits > 4.
- Output data: 8 bytes



Notice!

In this switch position, the address of the multiNet slave is also transmitted in the first two bytes of the data range!

16.13 Resetting the parameters (S4 switch position F)

To reset all parameters of the MA that can be configured with software (such as baud rate, IP address, dependent on type) to the factory settings, do the following:

- ↳ *Set device switch S4 to F in a voltage free state.*
- ↳ *Switch the voltage on and wait until it is ready for operation.*
- ↳ *If necessary, switch the voltage off to prepare for commissioning.*
- ↳ *Set service switch S10 to the "RUN" position.*

17 Appendix

17.1 ASCII Table

HEX	DEC	CTRL	ABB	DESIGNATION	MEANING
00	0	^@	NUL	NULL	Zero
01	1	^A	SOH	START OF HEADING	Start of heading
02	2	^B	STX	START OF TEXT	Start of text characters
03	3	^C	ETX	END OF TEXT	Last character of text
04	4	^D	EOT	END OF TRANSMISSION	End of transmission
05	5	^E	ENQ	ENQUIRY	Request to transmit data
06	6	^F	ACK	ACKNOWLEDGE	Positive acknowledgment
07	7	^G	BEL	BELL	Bell signal
08	8	^H	BS	BACKSPACE	Backspace
09	9	^I	HT	HORIZONTAL TABULATOR	Horizontal tabulator
0A	10	^J	LF	LINE FEED	Line feed
0B	11	^K	VT	VERTICAL TABULATOR	Vertical tabulator
0C	12	^L	FF	FORM FEED	Form feed
0D	13	^M	CR	CARRIAGE RETURN	Carriage return
0E	14	^N	SO	SHIFT OUT	Shift out
0F	15	^O	SI	SHIFT IN	Shift in
10	16	^P	DLE	DATA LINK ESCAPE	Data link escape
11	17	^Q	DC1	DEVICE CONTROL 1 (X-ON)	Device control character 1
12	18	^R	DC2	DEVICE CONTROL 2 (TAPE)	Device control character 2
13	19	^S	DC3	DEVICE CONTROL 3 (X-OFF)	Device control character 3
14	20	^T	DC4	DEVICE CONTROL 4	Device control character 4
15	21	^U	NAK	NEGATIVE (/Tape) ACKNOWLEDGE	Negative acknowledge
16	22	^V	SYN	SYNCHRONOUS IDLE	Synchronization
17	23	^W	ETB	END OF TRANSMISSION BLOCK	End of data transmission block
18	24	^X	CAN	CANCEL	Invalid
19	25	^Y	EM	END OF MEDIUM	End of medium
1A	26	^Z	SUB	SUBSTITUTE	Substitution
1B	27	^[ESC	ESCAPE	Escape
1C	28	^\ ^]	FS GS	FILE SEPARATOR GROUP SEPARATOR	File separator Group separator
1D	29	^]	GS	GROUP SEPARATOR	Group separator
1E	30	^^	RS	RECORD SEPARATOR	Record separator
1F	31	^_ ^_	US US	UNIT SEPARATOR	Unit separator
20	32		SP	SPACE	Space
21	33		!	EXCLAMATION POINT	Exclamation point
22	34		"	QUOTATION MARK	Quotation mark
23	35		#	NUMBER SIGN	Number sign
24	36		\$	DOLLAR SIGN	Dollar sign
25	37		%	PERCENT SIGN	Percent sign
26	38		&	AMPERSAND	Ampersand
27	39		'	APOSTROPHE	Apostrophe
28	40		(OPENING PARENTHESIS	Opening parenthesis

HEX	DEC	CTRL	ABB	DESIGNATION	MEANING
29	41)	CLOSING PARENTHESIS	Closing parenthesis
2A	42		*	ASTERISK	Asterisk
2B	43		+	PLUS	Plus sign
2C	44		,	COMMA	Comma
2D	45		-	HYPHEN (MINUS)	Hyphen (minus)
2E	46		.	PERIOD (DECIMAL)	Period (decimal)
2F	47		/	SLANT	Slant
30	48		0		
31	49		1		
32	50		2		
33	51		3		
34	52		4		
35	53		5		
36	54		6		
37	55		7		
38	56		8		
39	57		9		
3A	58		:	COLON	Colon
3B	59		;	SEMICOLON	Semicolon
3C	60		<	LESS THAN	Less than
3D	61		=	EQUALS	Equals
3E	62		>	GREATER THAN	Greater than
3F	63		?	QUESTION MARK	Question mark
40	64		@	COMMERCIAL AT	Commercial AT
41	65		A		
42	66		B		
43	67		C		
44	68		D		
45	69		E		
46	70		F		
47	71		G		
48	72		H		
49	73		I		
4A	74		J		
4B	75		K		
4C	76		L		
4D	77		M		
4E	78		N		
4F	79		O		
50	80		P		
51	81		Q		
52	82		R		
53	83		S		
54	84		T		
55	85		U		
56	86		V		
57	87		W		
58	88		X		

HEX	DEC	CTRL	ABB	DESIGNATION	MEANING
59	89		Y		
5A	90		Z		
5B	91		[OPENING BRACKET	Opening bracket
5C	92		\	REVERSE SLANT	Reverse slant
5D	93]	CLOSING BRACKET	Closing bracket
5E	94		^	CIRCUMFLEX	Circumflex
5F	95		_	UNDERSCORE	Underscore
60	96		`	GRAVE ACCENT	Grave accent
61	97		a		
62	98		b		
63	99		c		
64	100		d		
65	101		e		
66	102		f		
67	103		g		
68	104		h		
69	105		i		
6A	106		j		
6B	107		k		
6C	108		l		
6D	109		m		
6E	110		n		
6F	111		o		
70	112		p		
71	113		q		
72	114		r		
73	115		s		
74	116		t		
75	117		u		
76	118		v		
77	119		w		
78	120		x		
79	121		y		
7A	122		z		
7B	123		{	OPENING BRACE	Opening brace
7C	124			VERTICAL LINE	Vertical line
7D	125		}	CLOSING BRACE	Closing brace
7E	126		~	TILDE	Tilde
7F	127		DEL	DELETE (RUBOUT)	Delete

A		I	
Accessories	74	Input byte 0	
Bus connection cables	76	Buffer overflow	47
Cables for Leuze ident devices	78	Data exist	46
Connector	74	Data loss	47
Voltage supply cables	75	New data	48
ASCII Table	95	Next block ready to transmit	47
		Service mode active	46
		Write-Acknowledge	46
C		Input byte 1	
CANopen		Data length code	48
General information	17	Interface	
Interface	32	CANopen	32
Causes of errors			
General	72	L	
Interface	73	LED status indicators	34
Collective mode	14	Leuze device	
Command mode	14, 56	2D-code reader	
Commissioning	58	DCR 202i	87
Configuration	41, 58	LSIS 122	86
Connecting the Leuze device	11	LSIS 222	86
PCB connectors X30 ... X32	38	LSIS 4x2i	87
Connections		Bar code positioning system (BPS)	
PWR IN	28	BPS 300i	91
PWR OUT switching input/output	30	BPS 8	90
Control bytes	48	Bar code reader (BCL)	
		BCL 22	83
		BCL 300i	84
		BCL 500i	84
		BCL 600i	84
		BCL 8	82
		BCL 90	85
		BCL 900i	85
		Hand-held scanner	88
		Optical distance sensor (ODSL)	91
		RFID read-write devices (RFM/RFI ...)	
		RFM 12, 32 and 62	89
		Setting the read parameters	69
		Specific feature for hand-held scanners	70
		Specifications for Command mode	80
		Specifications for the serial interface	80
D		M	
Declaration of Conformity	5	Maintenance	79
Definition of terms	7	Mounting	
Description of functions	6	Device arrangement, selecting a mounting	
Device description	14	location	10, 26
Device interface RS 232	32		
Diagnosis	72		
Dimensioned drawings	22		
Disassembling	79		
Disposing	79		
E			
Electrical connection	10		
Connecting the Leuze device	11		
Power supply and bus cable	13, 60		
Safety notices	27		
F			
Fast commissioning	10		
Fieldbus systems	17		

Mounting the device	10, 25	Output bytes	48
O		Transparent mode	14
Operating modes		Troubleshooting	72
Operation	16	Type overview	23, 74
Service fieldbus gateway	16	W	
Service Leuze device	16	Writing slave data	53
Output byte 0			
Address bits 0 .. 4	49		
Broadcast	49		
Command mode	49		
New data	49		
Output byte 1			
Copy to transmit buffer	51		
Read-Acknowledge	50		
Send data from buffer	50		
P			
Packing	79		
Q			
Quality assurance	5		
R			
Reading slave data	53		
Repair	79		
S			
Service interface	33, 38		
Service mode			
Commands	42		
Information	42		
Service switch	38		
Servicing	79		
Specifications	21		
Electrical data	21		
Environmental data	21		
Indicators	21		
Mechanical data	21		
Starting the device	13, 60		
Status bytes	45		
Structure of the fieldbus telegram	44		
Symbols	5		
T			
Telegram structure			
Input bytes	45		